



**HIRSCHMANN**

A **BELDEN** BRAND

# User Manual

## Installation

### Fiberoptic Repeater

### OZD Profi 12M...

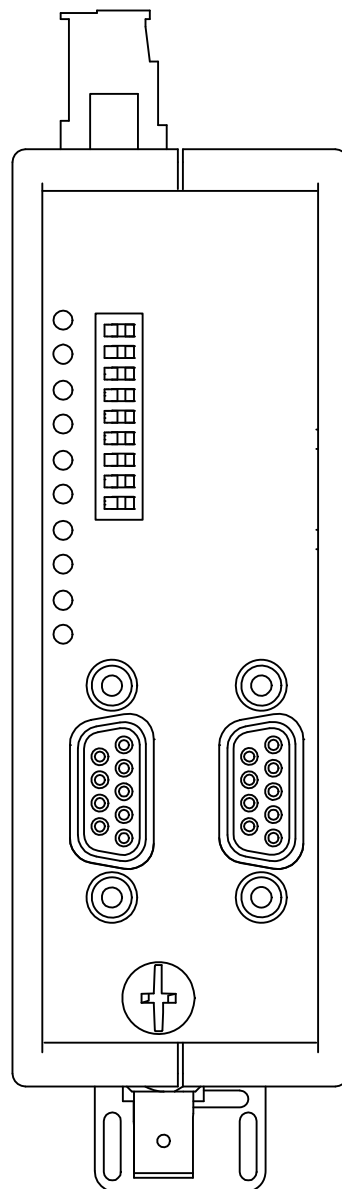
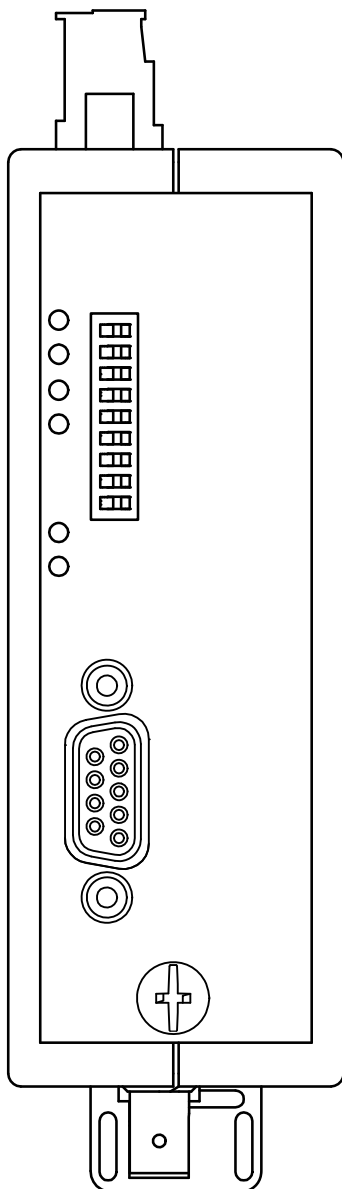

The naming of copyrighted trademarks in this manual, even when not specially indicated, should not be taken to mean that these names may be considered as free in the sense of the trademark and tradename protection law and hence that they may be freely used by anyone.

© 2023 Hirschmann Automation and Control GmbH

Manuals and software are protected by copyright. All rights reserved. The copying, reproduction, translation, conversion into any electronic medium or machine scannable form is not permitted, either in whole or in part. An exception is the preparation of a backup copy of the software for your own use.

The performance features described here are binding only if they have been expressly agreed when the contract was made. This document was produced by Hirschmann Automation and Control GmbH according to the best of the company's knowledge. Hirschmann reserves the right to change the contents of this document without prior notice. Hirschmann can give no guarantee in respect of the correctness or accuracy of the information in this document.

Hirschmann can accept no responsibility for damages, resulting from the use of the network components or the associated operating software. In addition, we refer to the conditions of use specified in the license contract.

You can get the latest version of this manual on the Internet at:  
<https://www.doc.hirschmann.com>

Hirschmann Automation and Control GmbH  
Stuttgarter Str. 45-51  
72654 Neckartenzlingen  
Germany

# Contents

Important information	5
Safety instructions	7
About this manual	17
Key	18
1    Description	19
1.1    Non operating mode related functions	22
1.2    Operating mode related functions	23
1.2.1    Segment monitoring at the RS 485 port	23
1.3    Device views	25
1.4    Display elements	27
2    Network Topologies	31
2.1    Line topology	31
2.1.1    Line topology with optical fiber link monitoring and segmentation	32
2.1.2    Line topology without optical fiber link monitoring	33
2.2    Star topology	34
2.3    Redundant ring	36
3    Installation guidelines	38
3.1    Electromagnetic compatibility (EMC)	38
3.2    Interference suppression of switched inductances	38
3.2.1    Suppressing switched inductances with fuses	38
3.2.2    Cabinet lighting	38
3.3    Arrangement of devices and cables	39
3.3.1    Reducing interference by providing adequate space	39
3.3.2    Standard recommendations for the arrangement of devices and cables	39
3.3.3    Using bus line shields	39
3.3.4    Shield connections	40
3.4    Laying cables inside of buildings	41

3.5	Laying cables outside of buildings	42
4	Installation	44
4.1	Checking the package contents	44
4.2	Mounting the device	45
	4.2.1 Installing the device onto the DIN rail	45
4.3	Setting compatibility	46
4.4	Setting the operating mode and transmitting power	49
	4.4.1 Setting the operating mode of the electrical ports (CH1, CH2)	49
	4.4.2 Setting the operating mode of the optical ports (CH3, CH4)	50
	4.4.3 Reducing the optical transmitting power	51
4.5	Connecting the optic bus cables	52
4.6	Connecting the electric bus cables	53
4.7	Connecting the function ground and the shield of the bus cable	55
4.8	Connecting the power supply	56
4.9	Connecting the signal contact (optional)	57
4.10	Connecting the analog voltage outputs (optional)	58
5	Configuration	60
6	Disassembly	62
7	Technical data	63
8	Scope of delivery, order numbers and accessories	68
9	Underlying technical standards	69
10	Help with problems	70
10.1	Troubleshooting	70
10.2	Systematic troubleshooting	71
10.3	Problem reporting	73
A	Further support	74

# Important information

**Note:** Read these instructions carefully, and familiarize yourself with the device before trying to install, operate, or maintain it. The following notes may appear throughout this documentation or on the device. These notes warn of potential hazards or call attention to information that clarifies or simplifies a procedure.

## ■ Symbol explanation



This is a general warning symbol. This symbol alerts you to potential personal injury hazards. Observe all safety notes that follow this symbol to avoid possible injury or death.



If this symbol is displayed in addition to a safety instruction of the type “Danger” or “Warning”, it means that there is a danger of electric shock and failure to observe the instructions will inevitably result in injury.



This symbol indicates the danger of hot surfaces on the device. In connection with safety instructions, non-observance of the instructions will inevitably result in injuries.



## DANGER

**DANGER** draws attention to an immediately dangerous situation, which will **inevitably** result in a serious or fatal accident if not observed.



## WARNING

**WARNING** indicates a potentially hazardous situation which, if not avoided, **could** result in death or serious injury.



## CAUTION

**CAUTION** indicates a possible danger which, if not avoided, **may** result in minor injuries.

# NOTICE

**NOTICE** provides information about procedures that do not involve the risk of injury.

# Safety instructions



## WARNING

### UNCONTROLLED MACHINE ACTIONS

To avoid uncontrolled machine actions caused by data loss, configure all the data transmission devices individually.

Before you start any machine which is controlled via data transmission, be sure to complete the configuration of all data transmission devices.

**Failure to follow these instructions can result in death, serious injury, or equipment damage.**

#### ■ General safety instructions

You operate this device with electricity. Improper usage of the device entails the risk of physical injury or significant property damage. The proper and safe operation of this device depends on proper handling during transportation, proper storage and installation, and careful operation and maintenance procedures.

- Before connecting any cable, read this document, and the safety instructions and warnings.
- Operate the device with undamaged components exclusively.
- The device is free of any service components. In case of a damaged or malfunctioning device, turn off the supply voltage and return the device to Hirschmann for inspection.

#### ■ Qualification requirements for personnel

- Only allow qualified personnel to work on the device.

Qualified personnel have the following characteristics:

- ▶ Qualified personnel are properly trained. Training as well as practical knowledge and experience make up their qualifications. This is the prerequisite for grounding and labeling circuits, devices, and systems in accordance with current standards in safety technology.
- ▶ Qualified personnel are aware of the dangers that exist in their work.
- ▶ Qualified personnel are familiar with appropriate measures against these hazards in order to reduce the risk for themselves and others.
- ▶ Qualified personnel receive training on a regular basis.

- Certified usage
  - Use the product only for the application cases described in the Hirschmann product information, including this manual.
  - Operate the product only according to the technical specifications.  
See [“Technical data” on page 63.](#)
  - Connect to the product only components suitable for the requirements of the specific application case.
  
- Device casing
 

Only technicians authorized by the manufacturer are permitted to open the casing.
  
- National and international safety regulations
 

Verify that the electrical installation meets local or nationally applicable safety regulations.
  
- Grounding the device
 

Functional grounding the device is by means of a separate connection on the device.

  - Ground the device before connecting any other cables.
  - Disconnect the grounding only after disconnecting all other cables.
  - Ground the device via the ground screw.
  
- Requirements for connecting electrical wires
  - Before connecting the electrical wires, **always** verify that the requirements listed are complied with.

---

**All** of the following requirements are complied with:

- ▶ The electrical wires are voltage-free.
  - ▶ The cables used are permitted for the temperature range of the application case.
- 

*Table 1: Requirements for connecting electrical wires*

- Requirements for connecting the signal contact
  - Before connecting the signal contact, **always** verify that the requirements listed are complied with.

---

**All** of the following requirements are complied with:

- ▶ The switched voltage complies with the requirements for a safety extra-low voltage (SELV) according to IEC 60950-1 or ES1 according to IEC/EN 62368-1.
  - ▶ The connected voltage is limited by a current limitation device or a fuse.  
Observe the electrical threshold values for the signal contact.  
See [“General technical data” on page 63.](#)
- 

*Table 2: Requirements for connecting the signal contact*



- Requirements for connecting the supply voltage
  - Before connecting the supply voltage, **always** verify that the requirements listed are complied with.

### Requirements

**All** of the following requirements are complied with:

- ▶ The supply voltage corresponds to the voltage specified on the type plate of the device.
- ▶ The power supply conforms to overvoltage category I or II.
- ▶ The power supply has an easily accessible disconnecting device (for example a switch or a plug). This disconnecting device is clearly identified. So in the case of an emergency, it is clear which disconnecting device belongs to which power supply cable.
- ▶ The cross-section of the ground conductor is the same size as or bigger than the cross-section of the power supply cables.
- ▶ Relevant for North America:  
The power supply cables are suitable for ambient air temperatures of at least +75 °C (+167 °F). The wires of the power supply cables are made of copper.

The wire diameter of the power supply cable is at least 0.75 mm<sup>2</sup> (North America: AWG18) on the supply voltage input.

The following requirements are **alternatively** complied with:

Alternative 1	The power supply complies with the requirements for a limited power source (LPS) according to IEC 60950-1 or ES1 + PS2 according to IEC/EN 62368-1.
Alternative 2	Relevant for North America: The power supply complies with the requirements according to NEC Class 2.
Alternative 3	<p><b>All</b> of the following requirements are complied with:</p> <ul style="list-style-type: none"> <li>▶ The power supply complies with the requirements for a safety extra-low voltage (SELV) according to IEC 60950-1 or ES1 according to IEC/EN 62368-1.</li> <li>▶ A back-up fuse suitable for DC voltage is located in the plus conductor of the power supply. The minus conductor is on ground potential. Otherwise, a back-up fuse is also located in the minus conductor. Regarding the properties of this back-up fuse: <a href="#">See “General technical data” on page 63.</a></li> </ul>

*Table 3: Requirements for connecting the supply voltage*

- Supply voltage  
Only switch on the device when the housing is closed.

■ ATEX directive 2014/34/EU – specific regulations for safe operation

The following applies to OZD devices if you operate them in areas with explosive gases according to ATEX directive 2014/34/EU:

List of standards:

EN IEC 60079-0:2018  
EN 60079-7:2015 + A1:2018  
EN IEC 60079-15:2019

Make sure that the device has the following label:



**II 3G Ex ec nC IIC T4 Gc      DEKRA 17ATEX0017 X**

**T4: 0 °C ≤ Ta ≤ +60 °C (+32 °F ≤ Ta ≤ +140 °F)**

- The equipment is suitable for use in an area with maximum pollution degree 2, as defined in EN 60664-1.
- Install the modules in a suitable enclosure according to EN IEC 60079-0 providing a degree of protection of at least IP54 according to EN 60529, taking into account the environmental conditions under which the equipment will be used.
- Provisions shall be made to prevent the rated voltage from being exceeded by transient disturbances of more than 119 V.
- Connectors shall be connected or disconnected exclusively in dead-voltage state.

■ UK regulation S.I. 2016 No. 1107

(as amended by S.I. 2019 No. 696) - Schedule 3A, Part 6

The following applies to OZD devices if you operate them in areas with explosive gases according to UK directive S.I. 2016 No. 1107:

List of standards:

EN IEC 60079-0:2018  
EN 60079-7:2015 + A1:2018  
EN IEC 60079-15:2019

Make sure that the device has the following label:



**II 3G Ex ec nC IIC T4 Gc      DEKRA 21UKEX0083 X**

**T4: 0 °C ≤ Ta ≤ +60 °C (+32 °F ≤ Ta ≤ +140 °F)**

- The equipment is suitable for use in an area with maximum pollution degree 2, as defined in EN 60664-1.
- Install the modules in a suitable enclosure according to EN IEC 60079-0 providing a degree of protection of at least IP54 according to EN 60529, taking into account the environmental conditions under which the equipment will be used.

- Provisions shall be made to prevent the rated voltage from being exceeded by transient disturbances of more than 119 V.
- Connectors shall be connected or disconnected exclusively in dead-voltage state.

- Relevant for use in explosion hazard areas (Hazardous Locations, Class I, Division 2)



Ordinary Location,  
Non-Hazardous Area,  
Non-Explosive Atmosphere



Explosive Atmosphere  
Class I Division 2  
Groups A, B, C, D  
Hazardous Location

OZD

Relay contacts:  
Equipment with nonincendive field wiring parameters.  
Polarity is not relevant.

The relay terminals are dependent upon the following  
Entity parameters:

$U_i$	$I_i$	$C_i$	$L_i$
30 V	90 mA	2 nF	1 $\mu$ H

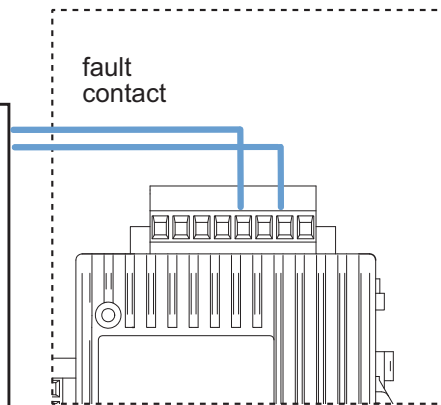

**For Use in Hazardous Locations Class I Division 2 Groups A, B, C, D:**

Only allowed for OZD model No's. which are individually labelled  
"FOR USE IN HAZARDOUS LOCATIONS"

Nonincendive field wiring circuits must be wired in accordance with the National Electrical Code (NEC), NFPA 70, article 501. CEC, Appendix J, Annex J 18

The earth conductor must be at least the same wire size (mm<sup>2</sup> or AWG) as the supply conductors.

**WARNING – EXPLOSION HAZARD – SUBSTITUTION OF ANY COMPONENTS MAY IMPAIR SUITABILITY FOR HAZARDOUS LOCATIONS OR EXPLOSIVE ATMOSPHERES.**

**WARNING – EXPLOSION HAZARD – DO NOT DISCONNECT EQUIPMENT UNLESS POWER HAS BEEN SWITCHED OFF OR THE AREA IS KNOWN TO BE NON-HAZARDOUS.**

Control Drawing for OZD devices according to Class I Division 2 Hazardous Locations

Rev.: 0

Document No.: 000212120DNR

Page 1/2

Capacitance and inductance of the field wiring from the nonincendive circuit to the associated apparatus shall be calculated and must be included in the system calculations as shown in Table 1. Cable capacitance,  $C_{\text{cable}}$ , plus nonincendive equipment capacitance,  $C_i$ , must be less than the marked capacitance,  $C_a$  (or  $C_o$ ), shown on any associated apparatus used.

The same applies for inductance ( $L_{\text{cable}}$ ,  $L_i$  and  $L_a$  or  $L_o$ , respectively). Where the cable capacitance and inductance per foot are not known, the following values shall be used:

$$C_{\text{cable}} = 60 \text{ pF/ft.}, L_{\text{cable}} = 0.2 \text{ }\mu\text{H/ft.}$$

**Table1:**

Nonincendive Equipment		Associated Apparatus
$V_{\text{max}}$ (or $U_i$ )	$\geq$	$V_{\text{oc}}$ or $V_t$ (or $U_o$ )
$I_{\text{max}}$ (or $I_i$ )	$\geq$	$I_{\text{sc}}$ or $I_t$ (or $I_o$ )
$P_{\text{max}}$ (or $P_i$ )	$\geq$	$P_o$
$C_i + C_{\text{cable}}$	$\leq$	$C_a$ (or $C_o$ )
$L_i + L_{\text{cable}}$	$\leq$	$L_a$ (or $L_o$ )

Suitability for installation in particular applications is at the discretion of the Authority Having Jurisdiction (AHJ).

## ■ CE marking

The labeled devices comply with the regulations contained in the following European directive(s):

### ▶ **2011/65/EU and 2015/863/EU (RoHS)**

Directive of the European Parliament and of the Council on the restriction of the use of certain hazardous substances in electrical and electronic equipment.

### ▶ **2014/30/EU (EMC)**

Directive of the European Parliament and of the Council on the harmonisation of the laws of the Member States relating to electromagnetic compatibility.

### ▶ **2014/34/EU (ATEX)**

Directive of the European Parliament and of the Council on the harmonisation of the laws of the Member States relating to equipment and protective systems intended for use in potentially explosive atmospheres.

In accordance with the above-named EU directive(s), the EU conformity declaration will be at the disposal of the relevant authorities at the following address:

Hirschmann Automation and Control GmbH  
Stuttgarter Str. 45-51  
72654 Neckartenzlingen  
Germany

You find the EU conformity declaration as PDF file for downloading on the Internet at: <https://www.doc.hirschmann.com/certificates.html>

The product can be used in the industrial sector.

- ▶ Interference immunity: EN 61000-6-2
- ▶ Emitted interference: EN 55032
- ▶ Safety: IEC 60950-1

You find more information on technical standards here:

[“Technical data” on page 63](#)

**Warning!** This is a class A device. This device can cause interference in living areas, and in this case the operator may be required to take appropriate measures.

**Note:** The assembly guidelines provided in these instructions must be strictly adhered to in order to observe the EMC threshold values.

■ UKCA marking

The labeled devices comply with the following UK regulations:

- ▶ **S.I. 2012 No. 3032**  
Restriction of the Use of Certain Hazardous Substances in Electrical and Electronical Equipment Regulations
- ▶ **S.I. 2016 No. 1091**  
Electromagnetic Compatibility Regulations
- ▶ **S.I. 2016 No. 1107**  
Equipment and Protective Systems Intended for use in Potentially Explosive Atmospheres Regulations

**Note:** The regulation applies exclusively to the device variants labeled with a UKEX certificate number: [See “UK regulation S.I. 2016 No. 1107 \(as amended by S.I. 2019 No. 696\) - Schedule 3A, Part 6” on page 10.](#)



The UKCA conformity declaration will be available to the relevant authorities at the following address:

Belden UK Ltd.

1 The Technology Centre, Station Road  
Framlingham, IP13 9EZ, United Kingdom

You find the UKCA conformity declaration as PDF file for downloading on the Internet at: <https://www.doc.hirschmann.com/certificates.html>

The product can be used in the industrial sector.

- ▶ Interference immunity: EN 61000-6-2
- ▶ Emitted interference: EN 55032
- ▶ Safety: IEC 60950-1

You find more information on technical standards here:

[“Technical data” on page 63](#)

**Warning!** This is a class A device. This device can cause interference in living areas, and in this case the operator may be required to take appropriate measures.

**Note:** The assembly guidelines provided in these instructions must be strictly adhered to in order to observe the EMC threshold values.

- LED or laser components  
LED or LASER components according to IEC 60825-1 (2014):  
CLASS 1 LASER PRODUCT  
CLASS 1 LED PRODUCT
- FCC note

### **Supplier's Declaration of Conformity 47 CFR § 2.1077 Compliance Information**

OZD Profi 12M...

#### **U.S. Contact Information**

Belden – St. Louis  
1 N. Brentwood Blvd. 15th Floor  
St. Louis, Missouri 63105, United States  
Phone: 314.854.8000

This device complies with part 15 of the FCC Rules. Operation is subject to the following two conditions: (1) This device may not cause harmful interference, and (2) this device must accept any interference received, including interference that may cause undesired operation.

**Note:** This equipment has been tested and found to comply with the limits for a Class A digital device, pursuant to part 15 of the FCC Rules. These limits are designed to provide reasonable protection against harmful interference when the equipment is operated in a commercial environment. This equipment generates, uses, and can radiate radio frequency energy and, if not installed and used in accordance with the instruction manual, may cause harmful interference to radio communications. Operation of this equipment in a residential area is likely to cause harmful interference in which case the user will be required to correct the interference at his own expense.

- Recycling note  
After usage, this device must be disposed of properly as electronic waste, in accordance with the current disposal regulations of your county, state, and country.





# About this manual

The “Installation” user manual contains a device description, safety instructions, a description of the display, and the other information that you need to install the device.

# Key

The symbols used in this manual have the following meanings:

	Listing
	Work step
	Subheading

# 1 Description

The PROFIBUS Repeaters are designed to be used in optical PROFIBUS field bus networks according to IEC 61784. They enable electrical PROFIBUS interfaces (RS 485 level) to be converted into optical PROFIBUS interfaces and vice-versa. By profiting from the familiar advantages of optical transmission technology, the repeaters can be integrated into existing PROFIBUS field bus networks. A complete PROFIBUS field bus network with repeaters in line, star or ring topology, and an arbitrary combination of these, can also be built up.

## ■ Device casing

The device is supplied in a metal housing. You have the option of mounting the device onto a DIN rail.

## ■ Glass fiber technology

The use of glass fiber transmission technology enables a very large transmission range and ensures optimal protection from EMC effects on the transmission path and due to the potential separation on the Repeater itself.

## ■ Transmission rate

The OZD Profi 12M... supports data rates from 9.6 kBit/s to 12 Mbit/s.

## ■ Redundancy

The redundant ring enables a very high level of transmission reliability. The redundant operating power supply can further improve the operating reliability.

## ■ Port

Depending on a device variant, each device has 2, 3, 4 mutually independent ports (channels), which in turn consist of a transmitting and a receiving component. The electric ports are a 9-pole D-Sub socket (female). A PROFIBUS bus segment can be connected to this ports. The optical ports are BFOC/2.5 (ST ®) sockets.

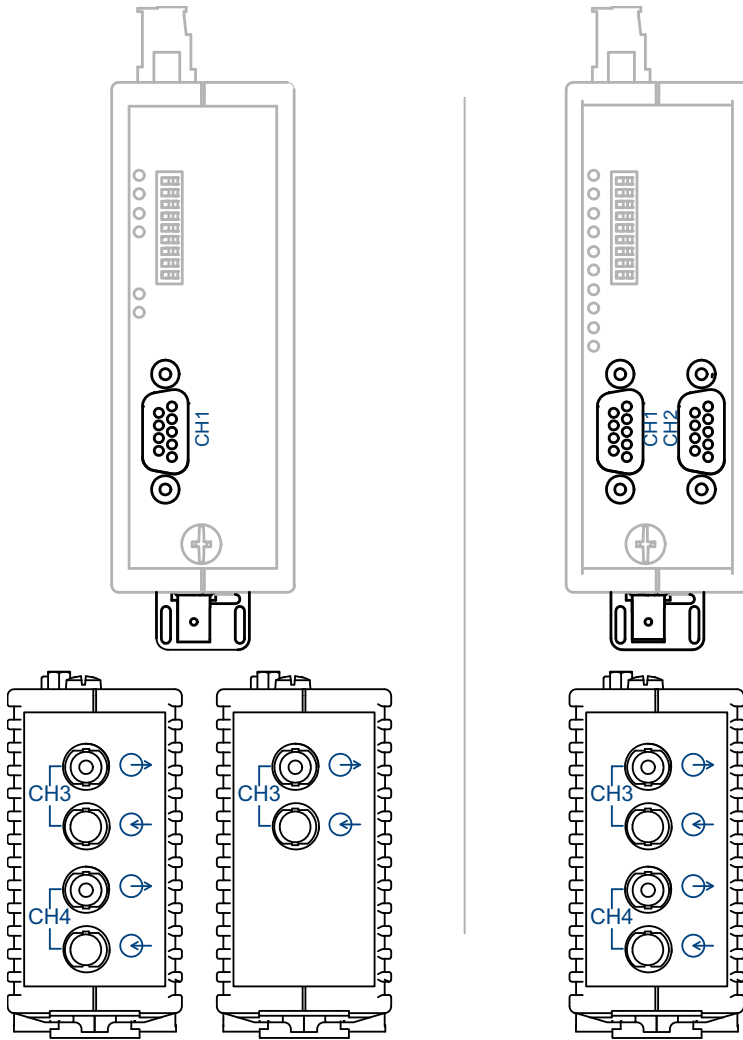

### ■ Power supply

The power supply is 24 V DC direct current. To improve the operating safety, a redundant operating power supply consisting of two separate sources can be used. For this purpose, you must connect the two supply voltages to two different terminals of the 8-pin screw-type terminal block. There is no load distribution between the sources. Both connections are uncoupled by means of diodes to prevent reverse voltage supply or destruction through incorrect pole connection. With redundant supply, the power supply unit with the higher output voltage must supply the repeater alone.

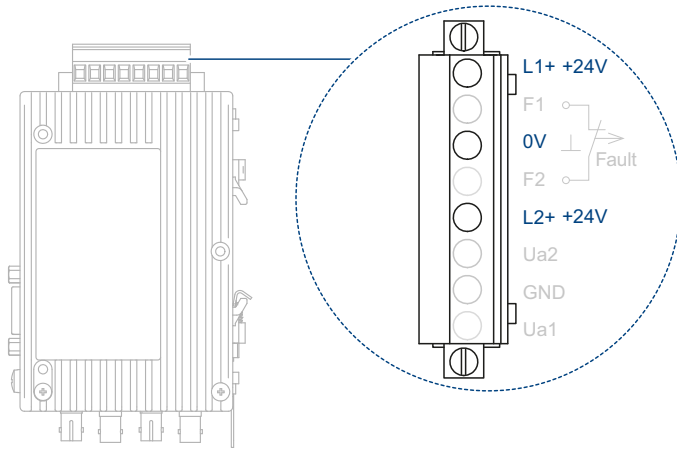

■ Signal contact

A signal contact (relay with unconnected contacts) is used to signal various disruptions in the repeaters. The signal contact is also connected to the 8-pin screw type terminal block.

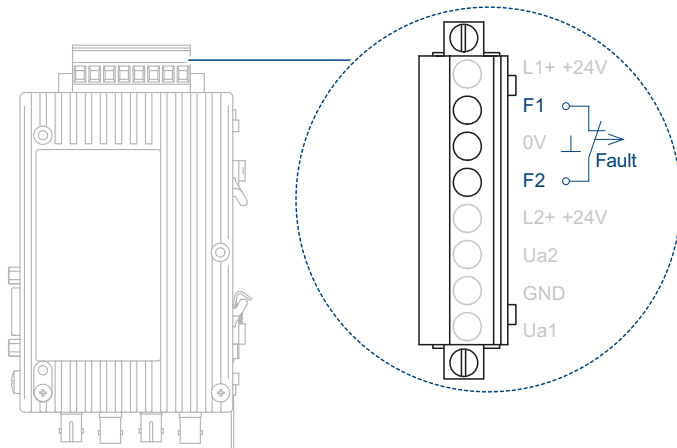

■ Measuring output

One measuring output is available for each optical port. The measuring output is connected to the 8-pin screw type terminal block.

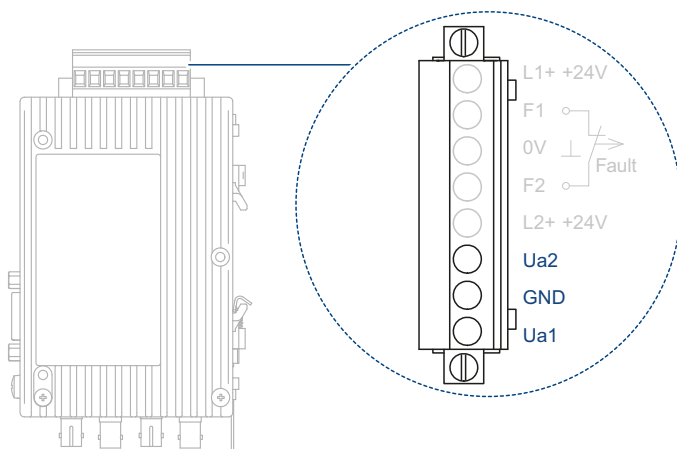

■ Configuration

You can easily set the configuration to meet your specific requirements by means of DIP switches, which can easily be operated from outside.

The following settings are possible:

- ▶ Setting the compatibility to OZD Profi ...a version  
[See “Setting compatibility” on page 46.](#)
- ▶ Setting the operating mode and transmit power  
[See “Setting the operating mode and transmitting power” on page 49.](#)
- ▶ Reducing the optical transmit power  
[See “Reducing the optical transmitting power” on page 51.](#)

## 1.1 Non operating mode related functions

### ■ Transmission rate

The OZD Profi 12M... support all the transmission rates defined in the EN 50170 standard:

- ▶ 9.6 kBit/s
- ▶ 19.2 kBit/s
- ▶ 45.45 kBit/s
- ▶ 187.5 kBit/s
- ▶ 500 kBit/s
- ▶ 1.5 MBit/s
- ▶ 3 MBit/s
- ▶ 6 MBit/s
- ▶ 12 MBit/s

The transmission rate is set automatically as soon as the OZD Profi 12M... receives a frame. The setting or adjustment is dependent on the transmission rate and the set operating mode. Depending on the OZD Profi 12M... this can last up to several seconds.

If the transmission speed has not been recognized, the outputs of all ports are blocked. If the transmission rate changes during operation, this is detected by the repeaters, which then automatically adjust their settings accordingly.

Transfer malfunctions may temporarily occur while the rate is being altered.

### ■ Signal regeneration

The repeaters regenerate the signal form and amplitude of the data received. This allows up to 122 OZD Profi 12M... to be cascaded (limited by the address space in PROFIBUS networks).

## ■ Help when setting up

At least one bus subscriber must be switched on and active in order to check the optical fiber connections during the installation. This bus subscriber serves as the frame source. The OZD Profi 12M... act passively when it is switched on. They recognize the transfer rate from the frames sent by the bus subscriber. An optical help when putting the device into operation is provided by the port LED which then lights up.

## 1.2 Operating mode related functions

The operating mode is set using switches located on the front of the repeater. A sticker attached to the side of the repeater provides assistance with the settings. The OZD Profi 12M... must be switched off when switching over DIP switches.

### 1.2.1 Segment monitoring at the RS 485 port

If the operating mode "Electric channel with segment monitoring" is set, each receiver monitors the RS 485 bus segment connected to it for faulty frames or continuously busy networks. If faulty frames are received by the receiver, or if the network is busy for longer than the maximum permitted send time, forwarding of the received signals is blocked until frames can be received again correctly, or if no signal is received for one second.

The RS-485 bus segment is not monitored in the operating mode "Electric port without segment monitoring". Interference from the electrical segment affects the entire network.

The following functions are only available for the optical channels. Whether the functions can be activated depends on the operating mode which has been set.

#### ■ Line monitoring with echoes

The repeaters enable the connected optical paths to be actively monitored for interruptions in the fiber line by means of the functions "Send echo", "Monitor echo" and "Suppress echo".

#### ■ Send echo

A frame which is received by a repeater via any port is transmitted to all other ports. If the receiving port is an optical port, the repeater sends the frame back to the corresponding optical sender.

### ■ Monitor echo

If a repeater sends a frame, no echo, to an optical port, the repeater expects to receive an echo. If the echo is not received after a predefined time, an echo monitoring error is indicated by a red LED belonging to the port.

### ■ Suppress echo

The relevant receiver is separated from the other ports from the moment a frame is sent until the echo has been received correctly.

### ■ Segmentation

If an echo monitoring error or a frame falsification arises at an optical port, the repeater assumes that the line is faulty and blocks this port for user data. The connected field bus partial network is then segmented (cut off). This segmentation causes the repeater at the other end of the optical fiber to be segmented as well. Both repeaters connected to the segmented field bus partial network send test frames to the segmented ports. These test frames – which are to be received regularly – can be used by both repeaters to check the status of the field bus partial network. The segmentation is automatically lifted as soon as the test frames indicate to both repeaters that the segmented field bus partial network is no longer disturbed. If all active bus subscribers are deactivated in a previously active network, the repeaters are segmented cyclically in order to check the fiber links to the neighboring repeaters. If there is no frame traffic, but the fiber links are intact, the port LEDs of the optical ports flash yellow cyclically.



## 1.3 Device views

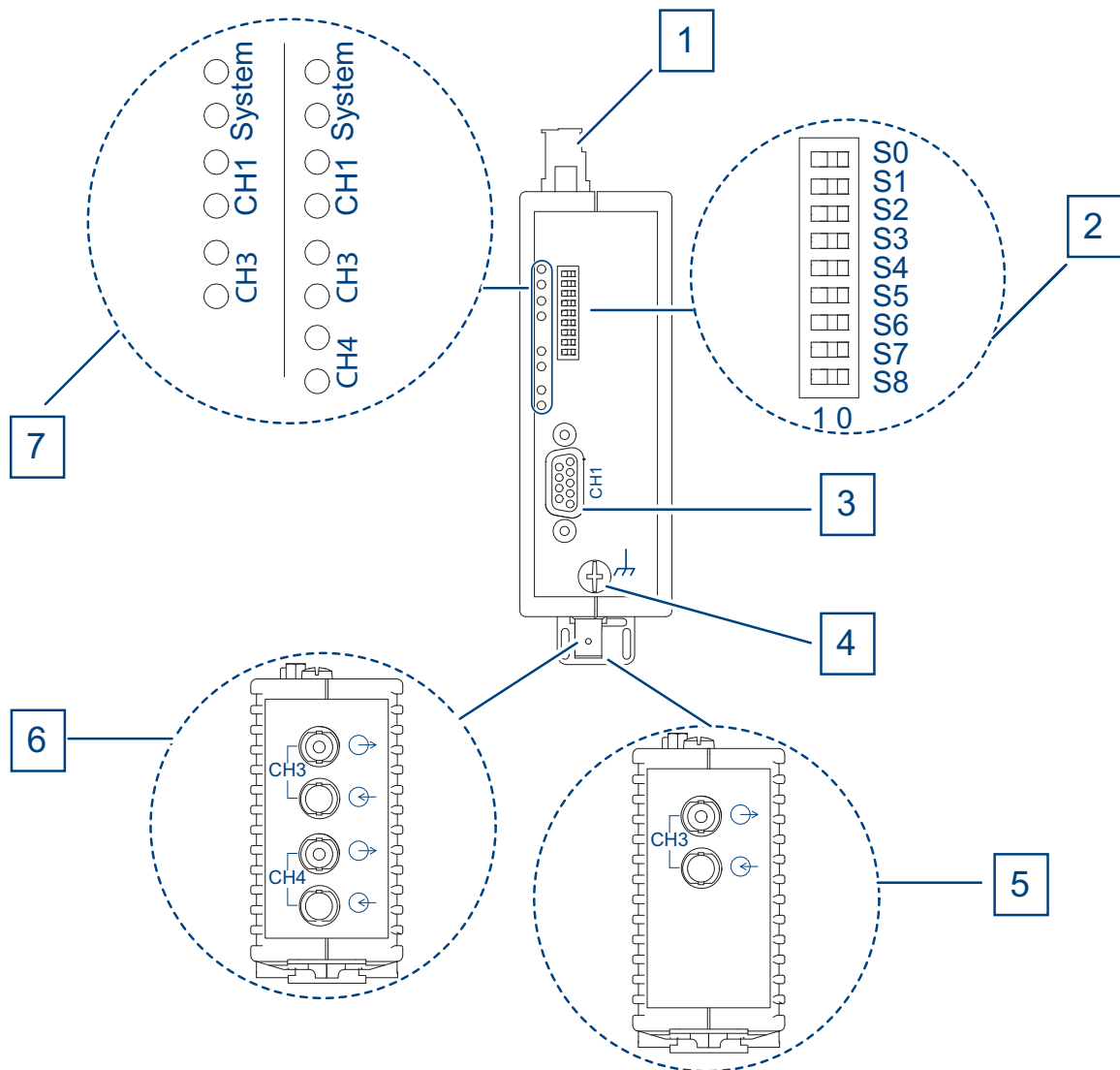

Front view using example of device variants OZD Profi 12M...

- **G11/G11-1300**
- **G12/G12-1300/G12-EEC/G12-1300-EEC**
- **P11/P12**

1	8-pin terminal block for power supply, signal contact, measuring output
2	8-pin DIP switch
3	CH1 - electrical port
4	Grounding screw
5	CH3 - optical port (only applies to the device variants OZD Profi 12M... G11, G11-1300, P11)
6	CH3, CH4 - optical ports (only applies to the device variants OZD Profi 12M... G12, G12-1300, G12 EEC, G12-1300 EEC, P12)
7	LED display element for system status and port status

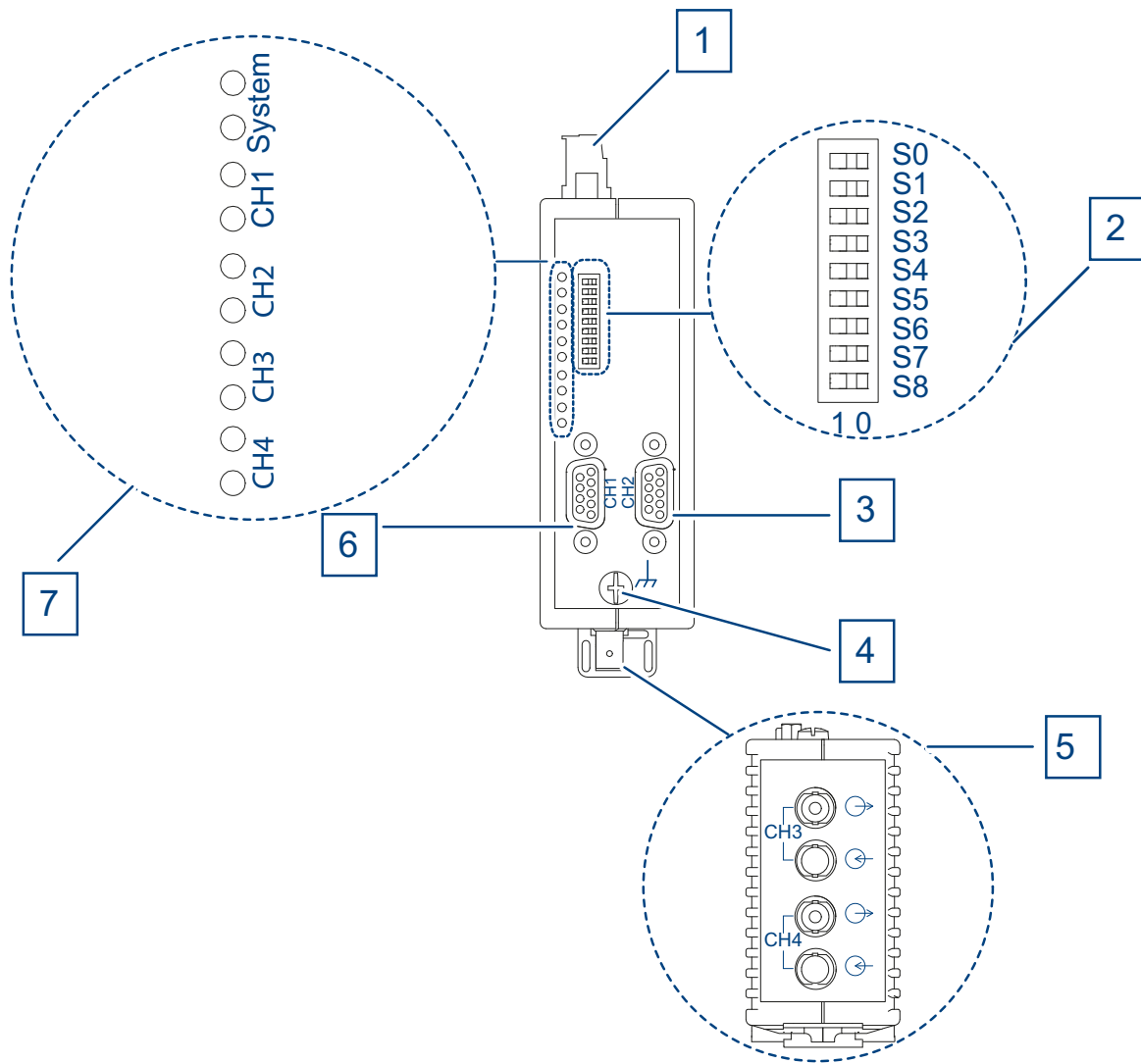

Front view using example of device variants OZD Profi 12M...

- **G22/G22-1300/G22-EEC/G22-1300-EEC**
- **P22**

- |   |   |
|---|---|
| 1 | 8-pin terminal block for power supply, signal contact, measuring output |
| 2 | 8-pin DIP switch  |
| 3 | CH2 - electrical port   |
| 4 | Grounding screw   |
| 5 | CH3, CH4 - optical ports  |
| 6 | CH1 - electrical port   |
| 7 | LED display element for system status and port status                   |

## 1.4 Display elements

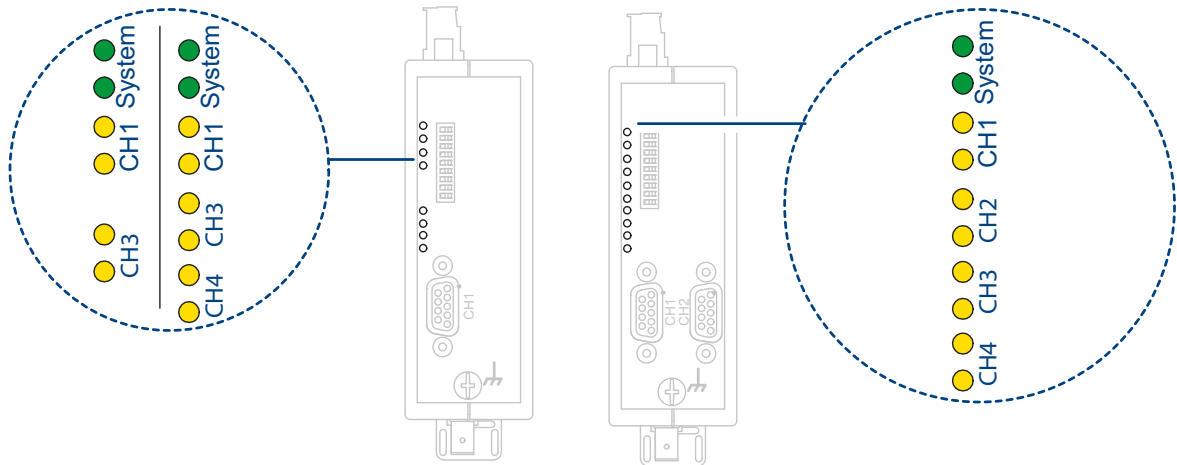

LED	Color	Meaning
System	green	lights up <ul style="list-style-type: none"> <li>▶ The transmission rate has been recognized and the power supply is in order</li> <li>▶ All existing data connections have been disconnected. The LED stays green until the OZD Profi 12M... is powered off.</li> </ul> <p><b>Signal contact:</b> no signal</p>
	red	flashes <ul style="list-style-type: none"> <li>▶ Transmission rate has not yet been recognized</li> <li>▶ No transmitting bus subscriber present</li> <li>▶ No connection to a partner repeater sending frames</li> <li>▶ Send and receive optical fibers have been transposed.</li> <li>▶ Transmission rate does not correspond to PROFIBUS-DP.</li> <li>▶ Only one active bus subscriber is connected, which is only sending tokens to itself. The indicator must switch over after a second bus subscriber has been activated (token frames on their own are not enough to set the transfer rate).</li> <li>▶ The connected RS-485 segment is only terminated at one end.</li> </ul> <p><b>Signal contact:</b> no signal</p>
	red/green	flashes <ul style="list-style-type: none"> <li>▶ Transmission rate recognized but</li> <li>▶ The network slot time could not be determined (network parameter HSA is set too low, no transmitting bus subscriber present)</li> <li>▶ one optical port is set to "Redundant optical ring" mode, but not the second (this operating mode must always be set at both optical ports)</li> <li>▶ the slot time of the network configuration is too short</li> </ul> <p><b>Signal contact:</b> no signal</p>
	none	<ul style="list-style-type: none"> <li>▶ Power supply has failed (total failure). Failure of both power supply sources with redundant infeed.</li> <li>▶ Power supply connected incorrectly</li> <li>▶ Repeater defective</li> </ul> <p><b>Signal contact:</b> signal</p>

LED	Color		Meaning
electrical ports	yellow	lights up	Signals are being received on the RS 485 bus line. <b>Signal contact:</b> no signal
	red	flashes/ lights up	Sporadic interference signals because <ul style="list-style-type: none"> <li>▶ the RS 485 bus line being shielded insufficiently</li> <li>▶ an open RS 485 bus line, i.e. it is only connected to the repeater at one end</li> <li>▶ the RS 485 segment is not terminated or only terminated at one end</li> <li>▶ an RS 485 bus terminal or terminal connector has been plugged in / pulled out</li> </ul> <b>Signal contact:</b> signal Permanent interference because <ul style="list-style-type: none"> <li>▶ conductors A and B in the RS-485 bus line have been transposed</li> <li>▶ of an RS-485 bus line short circuit</li> <li>▶ the send time has been exceeded caused by a bus subscriber in a bus segment connected to Port 1 (CH1)</li> </ul> <b>Signal contact:</b> signal <ul style="list-style-type: none"> <li>▶ repeater and another bus subscriber connected via Port 1 (CH1) are both sending at the same time (e.g. because an address has been assigned twice, the setting of the slot time is too low, or during lifting of the segmentation in the optical line)</li> <li>▶ RS 485 driver of the repeater is defective (e.g. after lightning strike)</li> </ul> <b>Signal contact:</b> no signal
			none
<b>Operating mode "Line with optical fiber link monitoring" and "Redundant optical ring"</b>			
optical ports	yellow	lights up	PROFIBUS frames are being received at the optical port <b>Signal contact:</b> no signal
		flashes	Transmission rate has been recognized – LED "System" lights green or flashes red/green <ul style="list-style-type: none"> <li>▶ No transmitting bus subscriber present (optical fiber connection is OK)</li> </ul> <b>Signal contact:</b> no signal

LED	Color	Meaning
	red lights up	<ul style="list-style-type: none"> <li>▶ Send and receive optical fibers have been transposed.</li> <li>▶ No partner repeater connected or partner repeater is not switched on.</li> <li>▶ Connected partner repeater is defective</li> <li>▶ Send time of connected partner repeater has been exceeded</li> <li>▶ An optical fiber line is broken</li> <li>▶ Optical fiber link to partner repeater is too long</li> <li>▶ Loose connection in an optical fiber connector</li> <li>▶ Optical fiber in the optical fiber connector is loose.</li> <li>▶ When using a redundant optical ring: if a fault in the optical fiber has been corrected but the port LEDs on both of the OZD Profi concerned still light red, check whether parameter HSA has been set as described in the chapter "Redundant Ring".</li> </ul> <p><b>Signal contact:</b> signal</p>
	red/yellow flashes	<ul style="list-style-type: none"> <li>▶ Fault occurs periodically (see above)</li> <li>▶ Loose connection in an optical fiber connector</li> <li>▶ Optical fiber in the optical fiber connector is loose</li> <li>▶ Only one active bus subscriber is connected, which is only sending tokens to itself. A fault should not be signaled as soon as a second subscriber is activated.</li> </ul> <p><b>Signal contact:</b> signal</p>
	none	<p>Transmission rate has not been recognized - LED "System" flashes red</p> <ul style="list-style-type: none"> <li>▶ No transmitting bus subscriber present</li> <li>▶ Send and receive optical fibers have been transposed</li> <li>▶ No partner repeater connected or partner repeater is not switched on</li> <li>▶ Connected partner repeater is defective</li> </ul> <p><b>Signal contact:</b> signal</p> <p>Transmission rate has been recognized - LED "System" flashes green</p> <ul style="list-style-type: none"> <li>▶ If the operating mode "Redundant optical ring" has been set, the optical port works as a stand-by port. There is no malfunction in the OZD Profi 12M... or the optical fiber.</li> <li>▶ If one of the operating modes "Line with optical fiber link monitoring ..." has been set, no PROFIBUS frames are received at the optical port. There is no malfunction in the OZD Profi 12M... or the optical fiber.</li> </ul> <p><b>Signal contact:</b> no signal</p>
<b>Operating mode "Line without optical fiber link monitoring"</b>		

LED	Color		Meaning
optical ports	yellow	lights up	Signals are received at the optical channel. <b>Signal contact:</b> no signal
	none		<ul style="list-style-type: none"> <li>▶ No transmitting bus subscriber present</li> <li>▶ Send and receive optical fibers have been transposed</li> <li>▶ No partner repeater connected or partner repeater is not switched on</li> <li>▶ Connected partner repeater is defective</li> </ul> <b>Signal contact:</b> no signal

## 2 Network Topologies

The following network topologies can be realized with the OZD Profi 12M...:

- ▶ Point-to-point connections
- ▶ Line topologies
- ▶ Star topology
- ▶ Redundant optical ring

### Note:

- ▶ Single terminals or entire PROFIBUS segments with max. 31 subscribers can be connected to the electrical interface of the OZD Profi 12M... .
- ▶ In areas with a high EMC incidence, only lay optical fiber lines in order to exclude the possibility of EMC affecting the whole network.
- ▶ Optically only OZD Profi 12M... of the same type can be connected together: OZD Profi 12M P11 with ... P12, OZD Profi 12M G11 with ...G12 and ...G12 EEC, OZD Profi 12M G11-1300 with ... G12-1300 and ...G12-1300 EEC.
- ▶ Optical ports which are connected by optical fiber must be set to the same operating mode.
- ▶ Junctions between different OZD Profi 12M... types are only possible via the RS 485 interface.
- ▶ OZD Profi 12M G12 (-1300) EEC can be used everywhere in those network topologies described below in which a OZD Profi 12M G12(-1300) can also be used.

### 2.1 Line topology

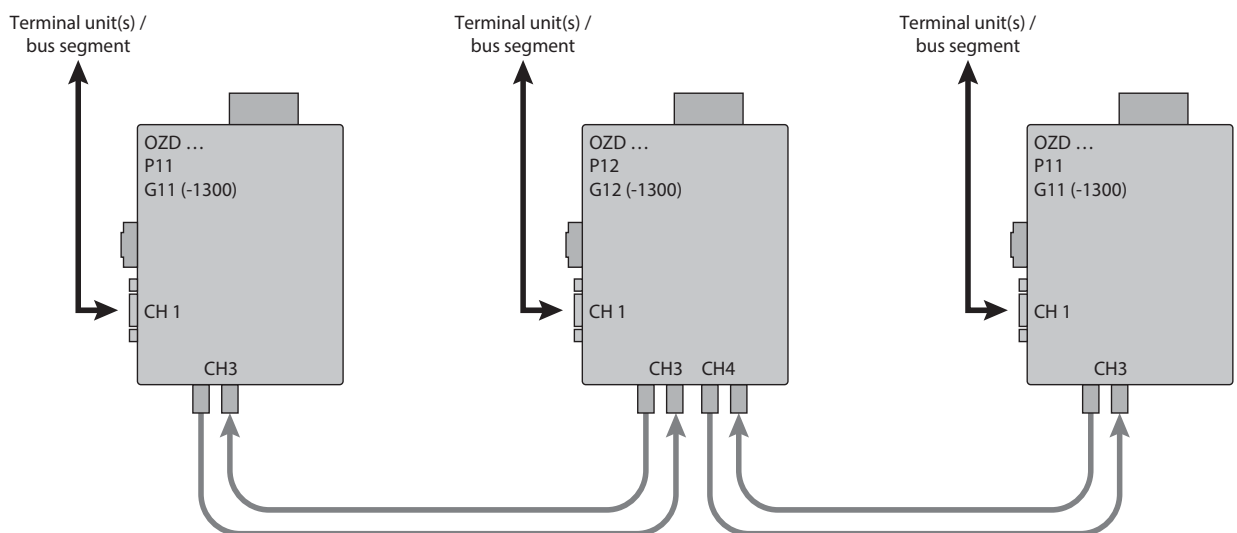

Figure 1: Network structure in an optical line topology

In a line structure, the individual OZD Profi 12M... are connected together by dual-fiber optical fibers. Repeaters with one optical port are sufficient at the beginning and end of a line, between which repeaters with two optical ports are necessary.

If single point-to-point connections are to be built up, this can be achieved using two repeaters each with one optical port.

The line topology can be realized with and without fiber link monitoring. If both operating modes are used within an optical fiber line, the operating mode "Line topology without fiber link monitoring" determines the availability of this fiber line. It is recommended that fiber link monitoring be used in homogeneous OZD Profi networks (default factory setting).

Please note that the following ambient conditions must be fulfilled to ensure that network configuration functions correctly:

- ▶ The parameter  $MIN T_{SDR}$  described in the PROFIBUS standard EN 50170 must be set to a value  $\geq 11$  on all terminals. This is usually the case, but the setting should be checked if communication malfunctions continuously arise.
- ▶ When configuring your network, select low bus subscriber addresses wherever possible. This ensures that master timeout times which may arise are kept as short as possible in the event of a malfunction.

### 2.1.1 Line topology with optical fiber link monitoring and segmentation

This operating mode should preferably be used if an interrupted fiber segment is to be separated from the rest of the network.

Monitoring mechanisms	
Send echo	yes
Monitor echo	yes
Suppress echo	yes
Monitor	yes
Segmentation	yes

In this operating mode the individual fiber links are monitored by the two connected repeaters.

If a repeater fails, an optical fiber breaks or faults are determined on the optical transfer link, the fiber link between the two Fiberoptic Repeater is interrupted (segmented).



The PROFIBUS network is divided into two partial networks, which remain functional independently of one another. The malfunction is indicated at the two OZD Profi 12M... that are connected to the malfunctioning fiber link by the port LEDs switching to red and by activation of the signaling contacts. The segmentation is lifted automatically as soon as both repeaters recognize that the field bus network is functioning correctly with the help of test frames.

Please note that in the case of networks with several active bus subscribers, two logical token rings are formed in the event of an error. Every time the partial networks are switched together, network malfunctions may arise due to the double tokens or frame collisions.

**Note:** If a repeater with two optical channels is used at the beginning or end of a line, the optical port which is not assigned must be switched to the operating mode "Line without fiber link monitoring", so that it does not signal a break in the fiber line. Please note that optical ports which are not connected must always be fitted with protective caps to guard against extraneous light and dirt.

### 2.1.2 Line topology without optical fiber link monitoring

Use this operating mode if you connect a OZD Profi 12M... with another optical fiber network component, which does not send a frame echo and does not expect or is not compatible with a frame echo in accordance with PROFIBUS guidelines (optical/electrical converter).

Monitoring mechanisms	
Send echo	no
Monitor echo	no
Suppress echo	no
Monitor	no
Segmentation	no

Individual fiber links are not monitored in this operating mode.

## 2.2 Star topology

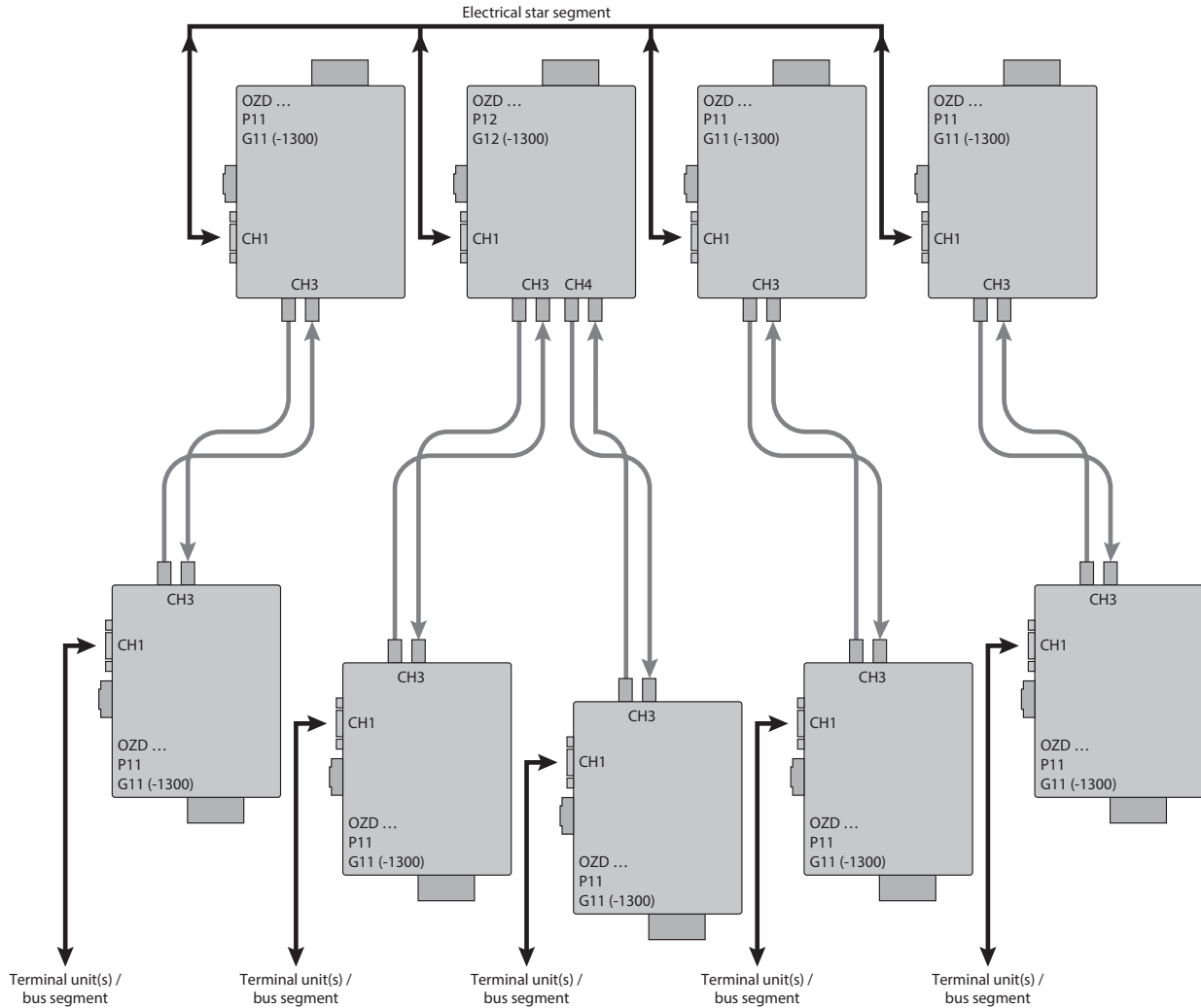

Figure 2: Network structure in an optic star topology

Several repeaters are combined to form an active PROFIBUS star coupler. Other repeaters are connected to this by dual-fiber optical fiber lines. The repeaters of the star coupler are connected to one another via the electrical port (electrical star segment). All OZD Profi 12M... types for different fiber types (plastic, PCF, glass) can be combined using the electrical star segment.

- ▶ CH1 in mode "Monitor off" (S0 = 1) must be activated on all OZD Profi 12M... which are connected to the electrical star segment. This deactivates the segmenting function of the RS 485 port on these OZD Profi 12M..., providing a high degree of availability of the electrical star segment.
- ▶ Ensure that the electrical star segment is wired carefully. Keep it as small as possible to avoid interference injection into the electrical star segment, and from here into the entire network. This can be achieved by laying out the OZD Profi 12M... in the electrical star segment directly next to each other on a hat rail.
- ▶ Switch on the terminating resistors in the bus port connectors at both ends of the electrical star segment.  
See ["Connecting the electric bus cables" on page 53.](#)
- ▶ Do not connect a bus subscriber to the electrical star segment wherever possible.
- ▶ This applies exclusively to device variants OZD Profi 12M x22:  
Connect other bus subscribers to the second electrical port (CH2).

Repeaters with one or two optical ports can be used to create an active PROFIBUS star coupler. Repeaters with one optical port are sufficient for connecting a terminal or an RS 485 bus segment to the active star coupler. If the link monitoring on the optical ports is activated, the fiber optic links are monitored by the respectively connected OZD Profi 12M... .

**Note:** Optical ports which are not assigned (for instance, because they are reserved for a future system extension) indicate a fiber break if the link monitoring is activated. You can prevent this error report from being issued by activating the operating mode "Line without fiber link monitoring" at the non-assigned ports. Please note that optical ports which are not connected must always be fitted with protective caps to guard against extraneous light and dirt.

## 2.3 Redundant ring

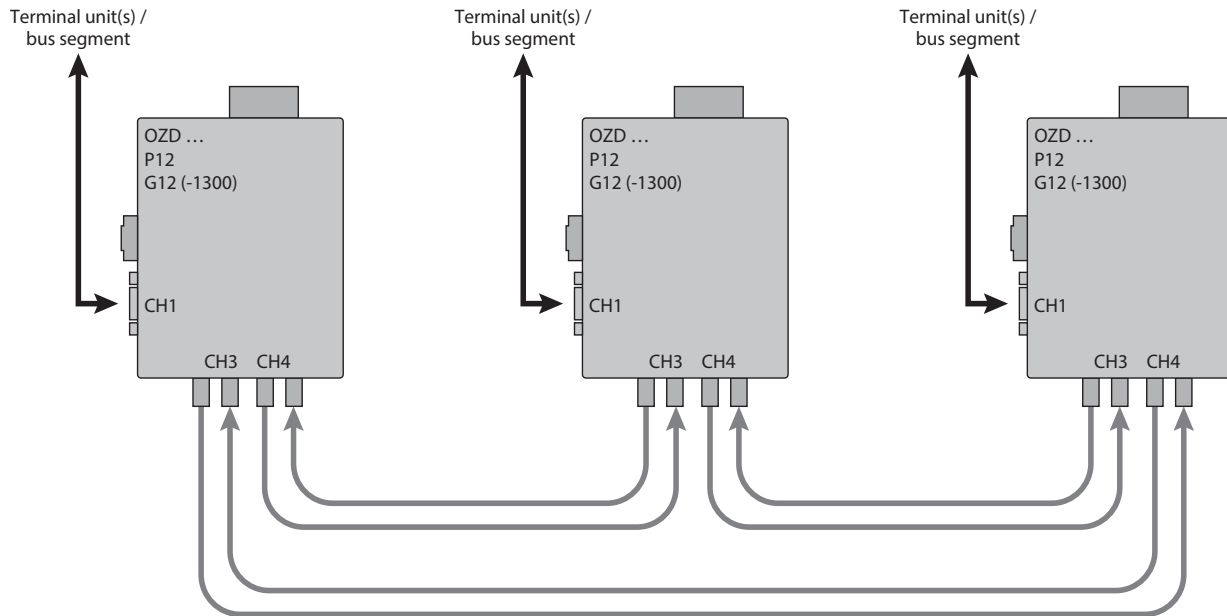

Figure 3: Network structure in a redundant optical ring topology

This network topology represents a special form of line topology. A high degree of network operating safety is achieved by "closing" the optical line. A redundant optical ring can only be realized with repeaters with two optical ports of the same fiber.

Monitoring mechanisms	
Send echo	yes
Monitor echo	yes
Suppress echo	yes
Monitor	yes
Segmentation	yes

An interruption of one or both optical fibers between two repeaters is detected by the OZD Profi 12M... and the ring is transformed into an optical line.

If one repeater fails only those terminals connected to this repeater or the RS-485 segment are uncoupled from the ring. The remainder of the network itself continues to function as a line. The error is indicated by the LEDs on the two OZD Profi 12M... connected to the malfunctioning optical fiber and their signaling contacts. The segmentation is lifted automatically as soon as both repeaters recognize that the field bus network is functioning correctly with the help of test frames. The line forms itself into a ring.

The following ambient conditions must be fulfilled to ensure that the network configuration functions correctly:

- ▶ The operating mode "Redundant optical ring" must be set at both optical ports of all the OZD Profi 12M... .
- ▶ All repeaters in a ring must be connected to one another by fiber lines. The ring may not include an RS-485 bus line.
- ▶ The parameter  $MIN T_{SDR}$  described in the PROFIBUS standard EN 50170 must be set to a value  $\geq 11$  on all terminals. This is usually the case, but the setting should be checked if communication malfunctions continuously arise.
- ▶ When configuring your network, select low bus subscriber addresses wherever possible. This ensures that master timeout times which may arise are kept as short as possible in the event of a malfunction.
- ▶ If a redundancy case occurs (e.g. a line break), there is a switching time during which data can not be correctly transmitted. In order to ensure a smooth transition, it is recommended that the frame repeat setting (Retry) on the PROFIBUS master be set to at least 3.
- ▶ After the error has been corrected, no frames should be present in the network when the optical line is transformed back into an optical ring to ensure that the process is completed smoothly. This condition can arise when a master selects a device whose address has been configured, but which does not physically exist.

The master tries to address this device cyclically and waits for a reply only until the configured slot time has been exceeded ("GAP request"). The OZD Profi 12M... recognizes this condition and closes the optical line to an optical ring in the middle of this request sequence. This results in two configuration requirements for the redundant optical ring:

- The value of the parameter HSA (Highest Station Address) must be set at all terminals so that between the bus address 0 and the value HSA at least one address in the network has not been assigned to a bus subscriber, i.e. so that there is at least one address gap. This address gap can also be created by simply setting the value of the parameter HSA so that it is at least one greater than the highest number of subscriber bus addresses present in the network.  
**Note:** If this requirement is not or no longer fulfilled, the optical line will no longer be closed into a redundant optical ring after segmentation. The error report (LED and signaling contact) of the two affected OZD Profi 12M... is not cancelled even after the error has been corrected.
- The slot time must be set to approximately twice the value required in a non-redundant network. Refer to the manufacturer's documentation provided with the terminal or configuration software for details about how to adjust the settings.

## 3 Installation guidelines

### 3.1 Electromagnetic compatibility (EMC)

Electromagnetic compatibility (EMC) covers all aspects regarding the effects of radiated and received electrical, magnetic, and electromagnetic emissions. In order to prevent interference in electrical systems, these effects must be reduced to a minimum. The structural design and correct connection of bus lines as well as the interference suppression of switched inductances play a major role in limiting interference.

### 3.2 Interference suppression of switched inductances

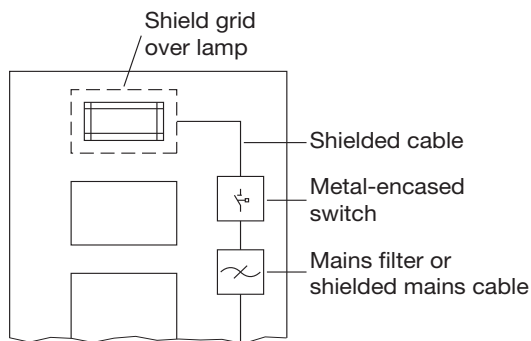

Figure 4: Interference suppression of fluorescent lamps in cabinet

#### 3.2.1 Suppressing switched inductances with fuses

Switching inductances, e.g. in relays and fans, generates interference voltages which are many times higher than the switched operating voltage. These interference voltages can affect electronic devices. The interference voltages of inductances must be limited at their source of emission by means of fuses (by connecting diodes or RC elements). Only use interference suppressors which are intended for the used relays and fans.

#### 3.2.2 Cabinet lighting

- Use filament lamps (e.g. LINESTRA lamps) for the cabinet lighting.
- Do not use fluorescent lamps because they generate interference fields. If the use of fluorescent lamps cannot be avoided, the interference suppression measures shown in Figure 4 must be implemented.

## 3.3 Arrangement of devices and cables

### 3.3.1 Reducing interference by providing adequate space

A simple yet effective way of reducing interference is to separate devices and cables causing interference from those affected by interference. Inductive and capacitive interference injection decreases by the square of the distance between the elements concerned. This means that doubling the distance reduces the interference by a factor of 4. If the arrangement of the various elements in a building or in the switch cabinet is taken into consideration at the planning stage, the cost of the necessary interference suppression measures is generally very low.

**Note:** Between an OZD Profi 12M... and a power switching element (e.g. contactor, relay, temperature regulator, switch, etc.) a minimum separation of 5.9 in (15 cm) is to be maintained. This minimum separation is to be measured between the outer edges of the components and in all directions around OZD Profi 12M... . The power supply wires (24 V DC and 0 V) for the OZD Profi 12M... must not be laid in the same cable duct as cables for load circuits. The wires (24 V DC and 0 V) should be twisted together.

### 3.3.2 Standard recommendations for the arrangement of devices and cables

EN 50174–2 contains recommendations for arranging devices and cables which are aimed at reducing mutual interference to a minimum.

### 3.3.3 Using bus line shields

It is important to observe the following when shielding bus lines:

- Use only fully shielded PROFIBUS lines. The shields of these lines must be of sufficient thickness to satisfy the legal requirements for interference radiated and interference received.
- Always attach the shields at both ends of the bus lines. The legal requirements vis-à-vis interference radiated and interference received for your system will only be satisfied if shields are connected at both ends (CE symbol).
- Attach the shield for the bus line at the connector plug housing or at the cable clamps provided.
- In the case of steady-state operation, it is advisable to strip the shielded line entirely and connect it with the shielding bus/protective conductor rail.

**Note:** If differences in potential occur between the grounding points, an inadmissibly high compensating current could flow across the shielding connected at both ends. Never eliminate this problem by removing the shielding from the bus line. The following solution is permissible: Lay an additional equipotential bonding cable parallel to the bus line. This additional cable will carry the shield current.

### 3.3.4 Shield connections

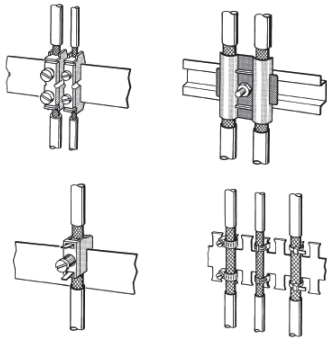

#### **Perform the following work steps:**

- Secure the shield braid using metal cable clamps.
- The clamps must fully enclose the shield and make good contact.
- Only connect the PROFIBUS lines via the copper braid shield, and not via the aluminum foil shield. One side of the foil shield is attached to a plastic film to increase its tearing strength, and is therefore non-conductive.
- The shields of all cables which are routed into a cabinet from the outside must be clamped at the point of entry inside the cabinet and connected to the cabinet ground with a large contact surface area.
- When removing the cable jackets, it is important to ensure that the braid shield of the cables is not damaged. Tin-plated or galvanically stabilized surfaces are ideal for optimum contacting between grounding elements. With zinc-plated surfaces, suitable threaded connections must be provided for the required contacts. Painted surfaces at the contact points are unsuitable.
- Shield clamps/contact points should not be used as strain relief devices. Contact with the shield bus could otherwise deteriorate or break completely.



## 3.4 Laying cables inside of buildings

### ■ Laying cables within control cabinets

If a repeater is installed within a control cabinet, the cable shield of the incoming bus cable should be electrically connected to a grounding rail as close as possible to the cable lead through using a shield grounding clamp or similar. The cable shield should continue within the cabinet to the fieldbus device and be connected there in accordance with the manufacturer's instructions.

### ■ Laying cables outside of control cabinets

PROFIBUS cables and cables for DC and AC voltages > 400 V (unscreened), areas with explosion hazard and telephone cables separate cable runs spaced at least 3.9 in (10 cm) apart. All cable ducts should be constructed of electrically conducting material and connected to functional ground at regular intervals. Bus cables should not be subject to mechanical loads which exceed the manufacturer's specifications. If this cannot be avoided, additional protective measures should be taken, e.g. by laying the cables in a steel pipe or rugged metal duct. The pipe or duct should then be grounded at regular intervals and protected against corrosion.

### ■ Potential equalization and screening

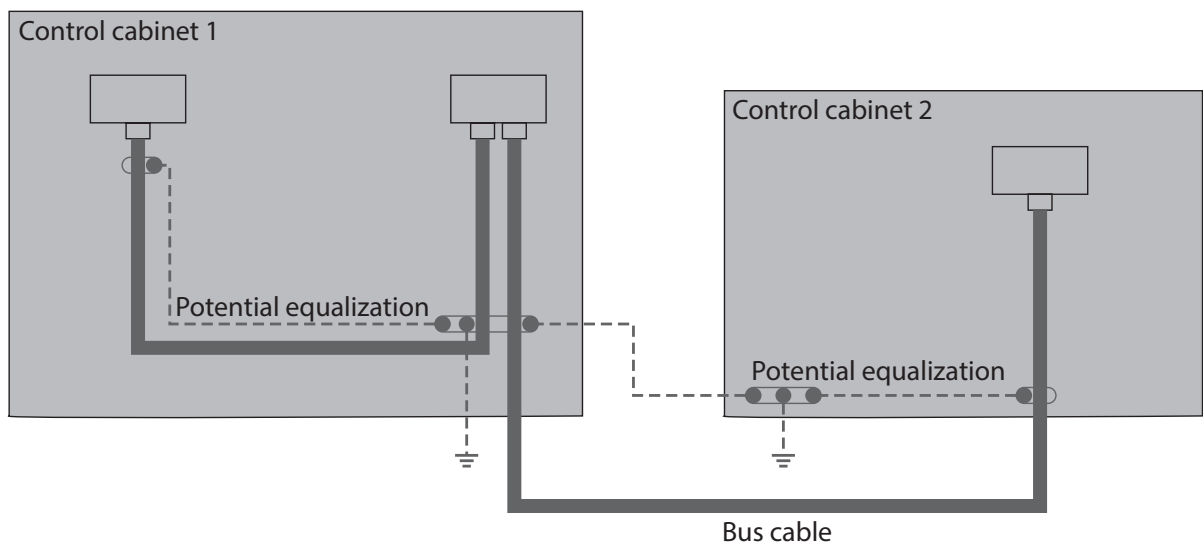

Figure 5: Laying cables inside of buildings

The cable screen should be connected to ground at both ends of the cable. The use of fiber optic cable is recommended if problems are experienced with interference. A low impedance potential equalization cable should be used if this is not possible. Situations where interference can present a problem include: plant which extends over a large area, power is fed to the plant from different power sources, networking extends over several buildings. If one of these situations applies, the following should be observed when installing the potential equalization system:

- ▶ The circuit through which interference signals flow must be closed.
- ▶ Each part of the plant must be electrically connected to the potential equalization system/functional ground at as many places as possible. Electrically conducting pipes, parts of machines or supporting structures should be integrated in the potential equalization system. In order to ensure long-term reliability, appropriate measures should be undertaken to protect against corrosion.
- ▶ The potential equalization cable must be protected against corrosion.
- ▶ The cross-section of the potential equalization cable should be chosen with regard to the maximum potential equalization currents which can flow.

Special care should be taken when installing potential equalization cables to maximize the interference immunity of the data cables. If possible, the potential equalization cable should be laid parallel to and as close as possible to the data cable (preferably in the same plastic pipe). The cable screen should never be used for potential equalization. The potential equalization cable should be finely stranded to ensure that it is also effective at high frequencies as a result of the large surface area.

### 3.5 Laying cables outside of buildings

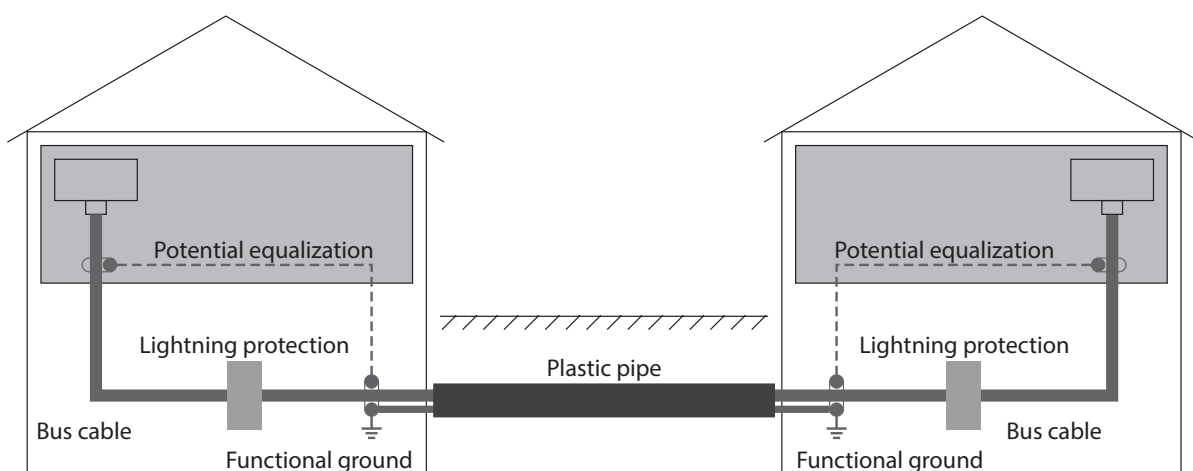

Figure 6: Laying cables outside of buildings

**Requirements:**

- It is recommended to use fiber optic cables for bus installations which are outside of buildings. In the case of bus cables between buildings which are laid in the ground, you should use a special fiber optic cable type which is suitable for this application.
- Suitable copper cable types can be used if fiber optic cables cannot be used.
- Observe the admissible minimum and maximum temperature rating for the type of cable used.

In principle, the same rules apply to laying cables outside of buildings as within buildings. However, for outside installation, the cables should be provided with additional protection by laying them inside a suitable plastic pipe.

The transition from external to internal cables should always use an auxiliary terminal block. It is used to interconnect the cable for burial in the ground with the standard bus cable. Lightning arrestors should be installed directly where the cable enters the building. In addition, the auxiliary terminal block should contain appropriate circuits to protect against overvoltages (lightning protection).

## 4 Installation

The devices have been developed for practical application in a harsh industrial environment.

Hirschmann supplies the device ready for operation.

To install the device, perform the following work steps:

- ▶ [Checking the package contents](#)
- ▶ [Mounting the device](#)
- ▶ [Setting compatibility](#)
- ▶ [Connecting the optic bus cables](#)
- ▶ [Connecting the electric bus cables](#)
- ▶ [Connecting the function ground and the shield of the bus cable](#)
- ▶ [Connecting the power supply](#)
- ▶ [Connecting the signal contact \(optional\)](#)
- ▶ [Connecting the analog voltage outputs \(optional\)](#)

### 4.1 Checking the package contents

**Perform the following work steps:**

- Check whether the package includes all items named in the section [“Scope of delivery” on page 68](#).
- Check the individual parts for transport damage.

## 4.2 Mounting the device

### 4.2.1 Installing the device onto the DIN rail

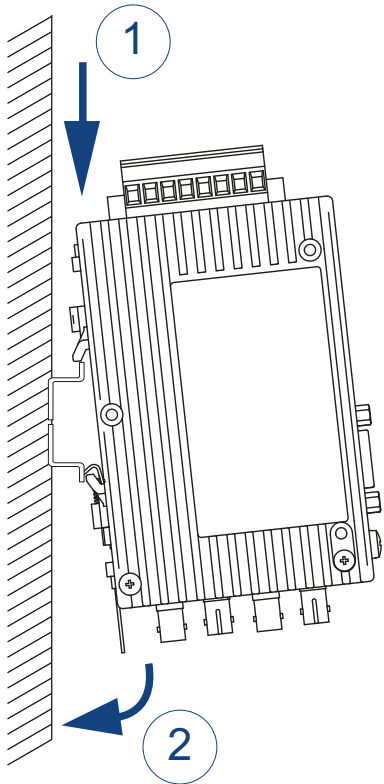

**Note:** The device is for mounting on a 35 mm DIN rail in accordance with DIN EN 60715.

#### Requirements:

- Install the device in a location where the climatic threshold values specified in the technical data are adhered to.  
[See “Technical data” on page 63.](#)
- Ensure that there is sufficient room to connect the bus and power supply cabling.
- Connect the optical fiber line before mounting the repeater as this simplifies the procedure.

#### Perform the following work steps:

- Slide the upper snap-in guide of the device into the DIN rail.
- Press the device downwards onto the clip-in bar.

## 4.3 Setting compatibility

**Note:** The functional compatibility on **OZD Profi 12M...**<sup>a</sup> is switched on or switched off with the DIP switch S8.

- ▶ When operating **OZD Profi 12M...**<sup>b</sup> with **OZD Profi PRO** or with previous **OZD Profi 12M...**<sup>c</sup> the functional compatibility must be switched off (S8=0). The devices are directly compatible. The devices are directly compatible.
- ▶ When operating **OZD Profi 12M...**<sup>d</sup> with **OZD Profi G3a, ... G4a, ... G3a-1300, ... G4a-1300, ... P3a, ... P4a** the functional compatibility must be switched on (S8=1).

Only turn switch S8 to Position 1 if the **OZD Profi 12M...**<sup>e</sup> is being used as a spare or expansion device in existing networks in conjunction with these devices and a direct optical connection is to be made. Tables [table 4 on page 47](#) and [table 5 on page 47](#) show the switch assignment.

- a. Device variants with 1 or 2 electrical ports (CH1, CH2), DIP switch: S0 - S8
- b. Device variants with 1 or 2 electrical ports (CH1, CH2), DIP switch: S0 - S8
- c. Device variants with 1 electrical port (CH1) only, DIP switch: S0 - S7
- d. Device variants with 1 or 2 electrical ports (CH1, CH2), DIP switch: S0 - S8
- e. Device variants with 1 or 2 electrical ports (CH1, CH2), DIP switch: S0 - S8

OZD Profi G3a... / G4a...			OZD Profi 12M... <sup>a</sup>	
Meaning of the DIP switches	DIP switch	Function	DIP switch	Function
S1 - Mode	S1 = 0	Mode 0	S2 = 0	Mode 0
	S1 = 1	Mode 1	S2 = 1	Mode 1
S2 - Redundancy function	S2 = 0	<b>OFF</b>	S3 = 0	<b>OFF</b>
	S2 = 1	<b>ON</b>	S3 = 1	<b>ON</b>
S3 - Termination	S3 = 0	CH2 not terminated	–	not relevant (Termination extern)
	S3 = 1	CH2 terminated		
S4 - Termination	S4 = 0	CH2 not terminated	–	not relevant (Termination extern)
	S4 = 1	CH2 terminated		
S5 - optical Power / Distance	S5 = 0	Network configuration: Standard	S4 = 0	Network configuration: Standard
	S5 = 1	Network configuration: Extended	S4 = 1	Network configuration: Extended
S6 - optical Power	S6 = 0	Without function	–	–
	S6 = 1	Without function	–	–
			S8 = 1	Compatibility ON
			S0, S5 = 0	Without function
			S6, S7 = 0	in position = 0

*Table 4: Switch assignment of the OZD Profi 12M... at S8=1 as a spare or expansion device for OZD Profi G3a, ...G4a, ...G3a-1300 and...G4a-1300.*

a. Device variants with 1 or 2 electrical ports (CH1, CH2)

OZD Profi P3a... / P4a...			OZD Profi 12M... <sup>a</sup>	
Meaning of the DIP switches	DIP switch	Function	DIP switch	Function

*Table 5: Switch assignment of the OZD Profi 12M... at S8=1 as a spare or expansion device for OZD Profi P3a, ...P4a, ...P3a-1300 and ...P4a-1300.*

OZD Profi P3a... / P4a...	OZD Profi 12M... <sup>a</sup>			
S1 - Mode	S1 = 0	Mode 0	S2 = 0	Mode 0
	S1 = 1	Mode 1	S2 = 1	Mode 1
S2 - Redundancy function	S2 = 0	<b>OFF</b>	S3 = 0	<b>OFF</b>
	S2 = 1	<b>ON</b>	S3 = 1	<b>ON</b>
S3 - Termination	S3 = 0	CH2 not terminated	-	not relevant
	S3 = 1	CH2 terminated		(Termination extern)
S4 - Termination	S4 = 0	CH2 not terminated	-	not relevant
	S4 = 1	CH2 terminated		(Termination extern)
S5 - optical Power / Distance	S5 = 0	CH3 - optical Power: Standard	S6 = 0	CH2 - optical Power: Standard
	S5 = 1	CH3 - optical Power: High	S6 = 1	CH2 - optical Power: High
S6 - optical Power	S6 = 0	CH4 - optical Power: Standard	S7 = 0	CH3 - optical Power: Standard
	S6 = 1	CH4 - optical Power: High	S7 = 1	CH3 - optical Power: High
			S8 = 1	Compatibility ON
			S0, S1, S4 = 0	Without function
			S5 = 0	in position 0

Table 5: Switch assignment of the OZD Profi 12M... at S8=1 as a spare or expansion device for OZD Profi P3a, ...P4a, ...P3a-1300 and ...P4a-1300.

a. Device variants with 1 or 2 electrical ports (CH1, CH2)



## 4.4 Setting the operating mode and transmitting power

### Note:

- ▶ S1 does not have a function on OZD Profi 12M... with only one electrical interface.
- ▶ S7 does not have a function on OZD Profi 12M... with only one optical interface.

The following details only apply for the S8 default position (S8 = 0).

- ▶ The DIP switch **S0** is used to set the operating mode of the electrical port **CH1**.
- ▶ The DIP switch **S1** is used to set the operating mode of the electrical port **CH2**.
- ▶ This applies exclusively to device variants OZD Profi 12M x22:  
The DIP switches **S2** and **S3** are used to set the operating mode of the optical port **CH3**.
- ▶ The DIP switches **S4** and **S5** are used to set the operating mode of the optical port **CH4**.

### 4.4.1 Setting the operating mode of the electrical ports (CH1, CH2)

- Operating mode: electrical ports (CH1, CH2) with segments monitoring

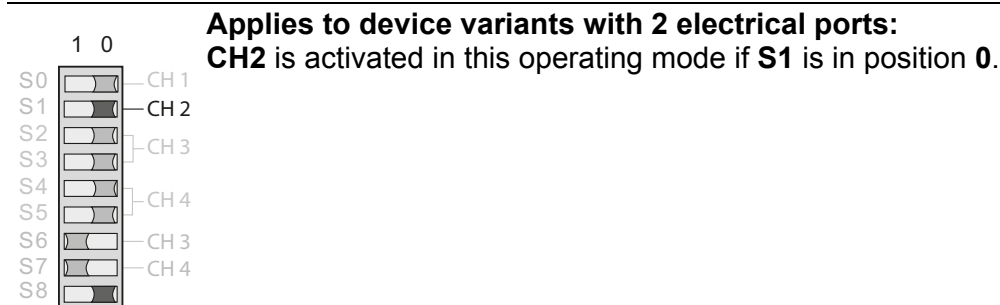
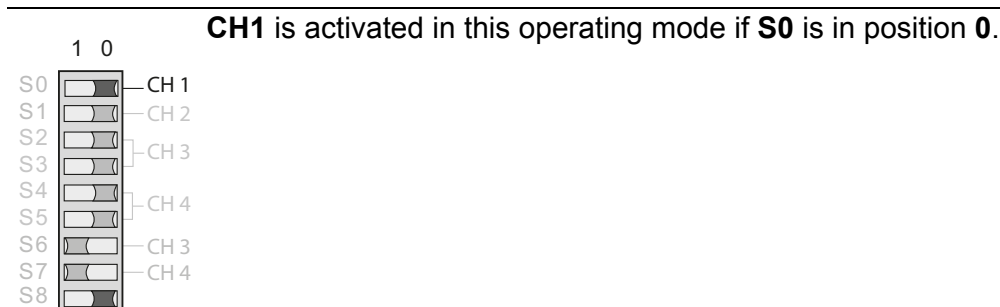

■ Operating mode: electrical ports (CH1, CH2) without segment monitoring

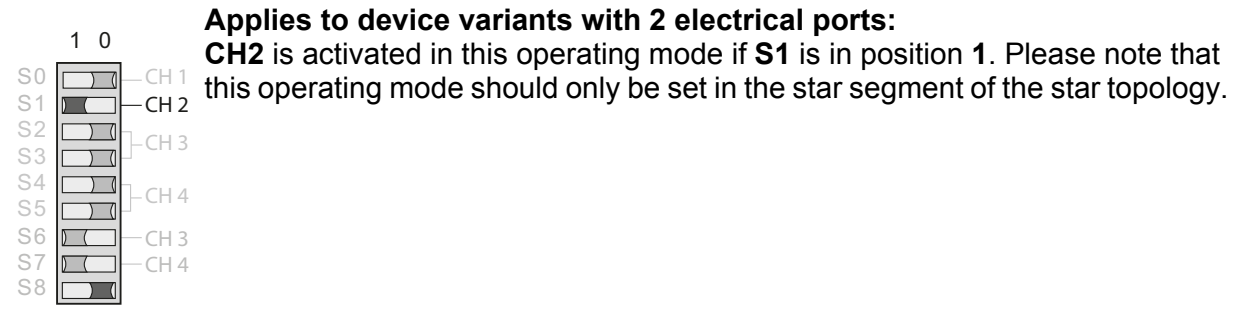
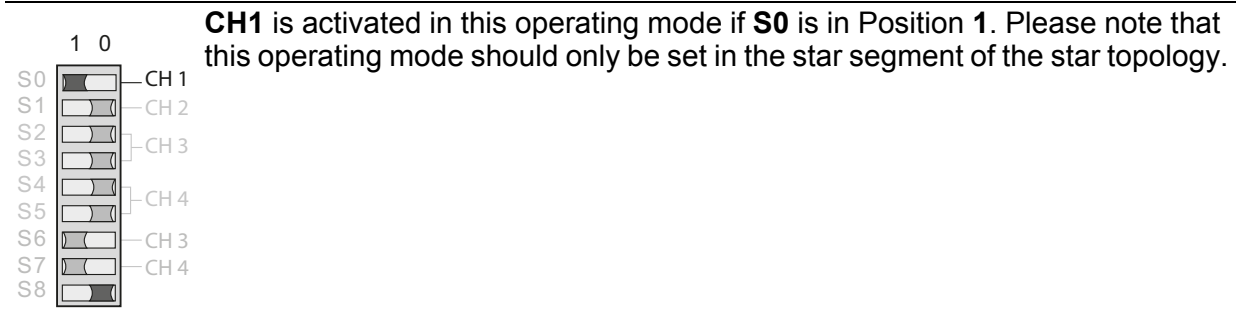

4.4.2 Setting the operating mode of the optical ports (CH3, CH4)

The operating mode can be set individually for each optical port. Combinations of the operating modes “Line with optical fiber link monitoring” and “Line without optical fiber link monitoring” are also possible. Note that the operating mode of the two optical ports which are connected by the fiber line must always have the same settings. The operating mode “Redundant optical ring” must always be set at both of the optical ports.

■ Operating mode: Line with optical fiber link monitoring and segmentation

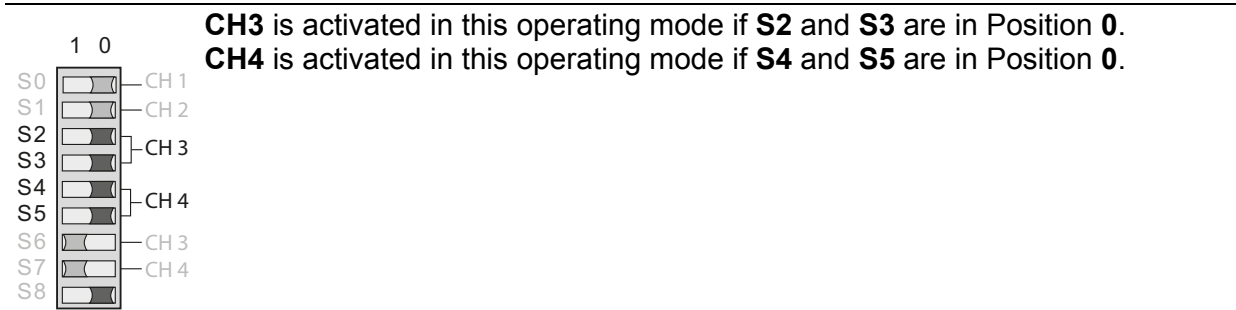

## ■ Operating mode "Line without optical fiber link monitoring"

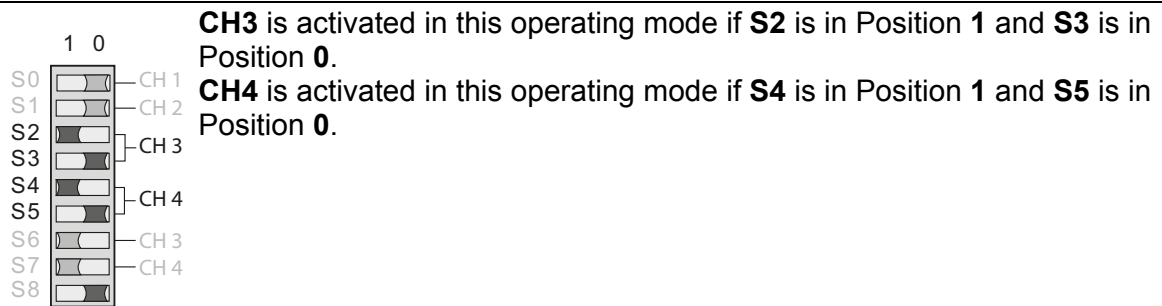

## ■ Operating mode: Redundant optical ring

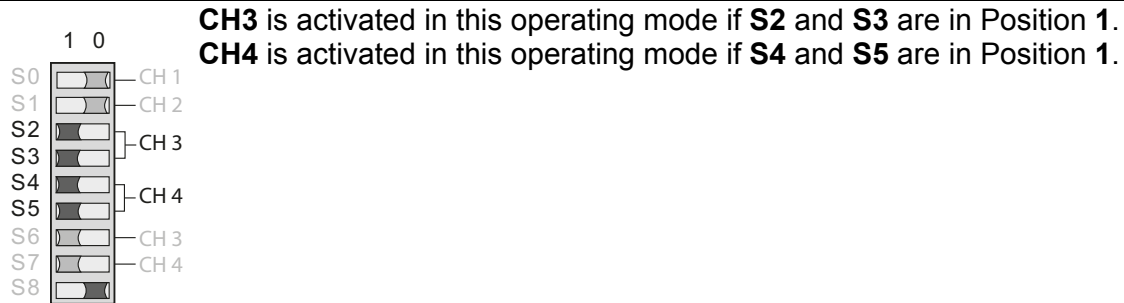

### 4.4.3 Reducing the optical transmitting power

The OZD Profi 12M P1x and OZD Profi 12M Gxx (EEC) have a high level of optical transmitting power. Optical overloading may result if these repeaters are connected with non-OZD Profi 12M... devices using plastic optical fiber cables, particularly if short cable lengths are used. In this case the optical transmitting power can be reduced.

The following details only apply for the S8 default position (S8 = 0).

- ▶ The DIP switch **S6** is used to set the transmitting power of **CH3**.
- ▶ The DIP switch **S7** is used to set the transmitting power of **CH4**.

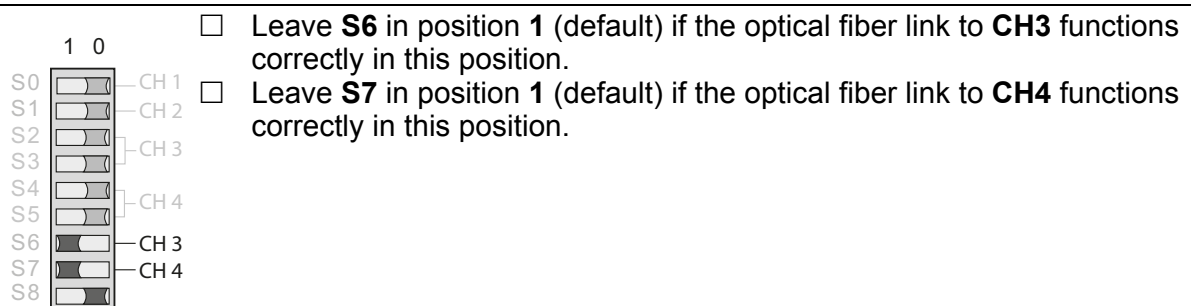

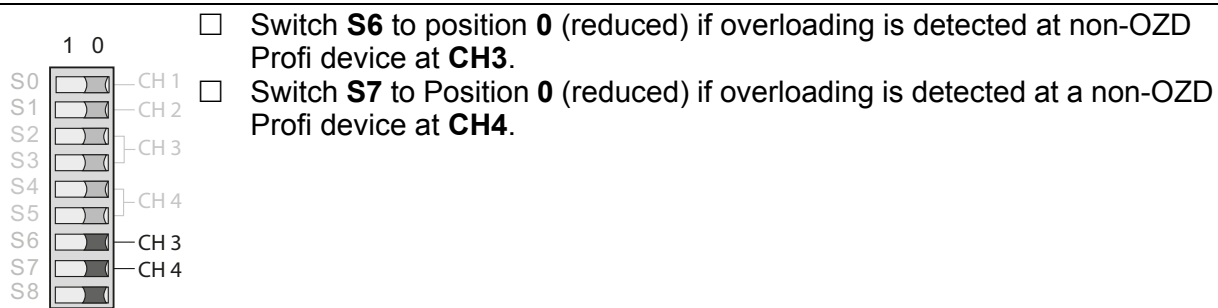

**Note:**

- ▶ When using OZD Profi 12M Gxx-1300 (EEC), transmit power must be set to Default (S6/S7 in position 1).
- ▶ When using PCF fibers, transmit power must be set to default (S6/S7 in position 1) for 660 nm.
- ▶ When using PCF fibers, transmit power must be set to default (S6/S7 in position 0) for 850 nm.
- ▶ S7 has no function on devices with only one optical port.

## 4.5 Connecting the optic bus cables

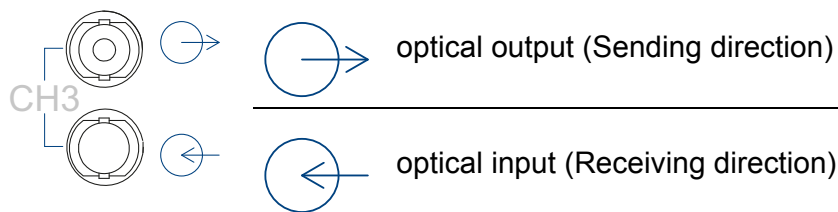

**Perform the following work steps:**

- Use a duplex fiber-optic cable with BFOC/2.5 (ST ®) connectors to connect the individual repeaters.
- Pay attention to the maximum cable length of the fiber-optic cable as well as the possible types of fibers specified in the Technical Data.
- Make sure that each optical input is connected to an optical output at the opposite end (“cross-overlink”). The corresponding BFOC sockets of the two ports are marked on the lower front panel.
- Ensure sufficient strain relief for the fiber-optic cables and pay attention to their minimum bend radiuses.
- Unused BFOC sockets are to be covered with the protective caps supplied. Incident ambient light and, in particular, great ambient brightness, can affect the network. The penetration of dust may impair operation of the optical components.

## 4.6 Connecting the electric bus cables

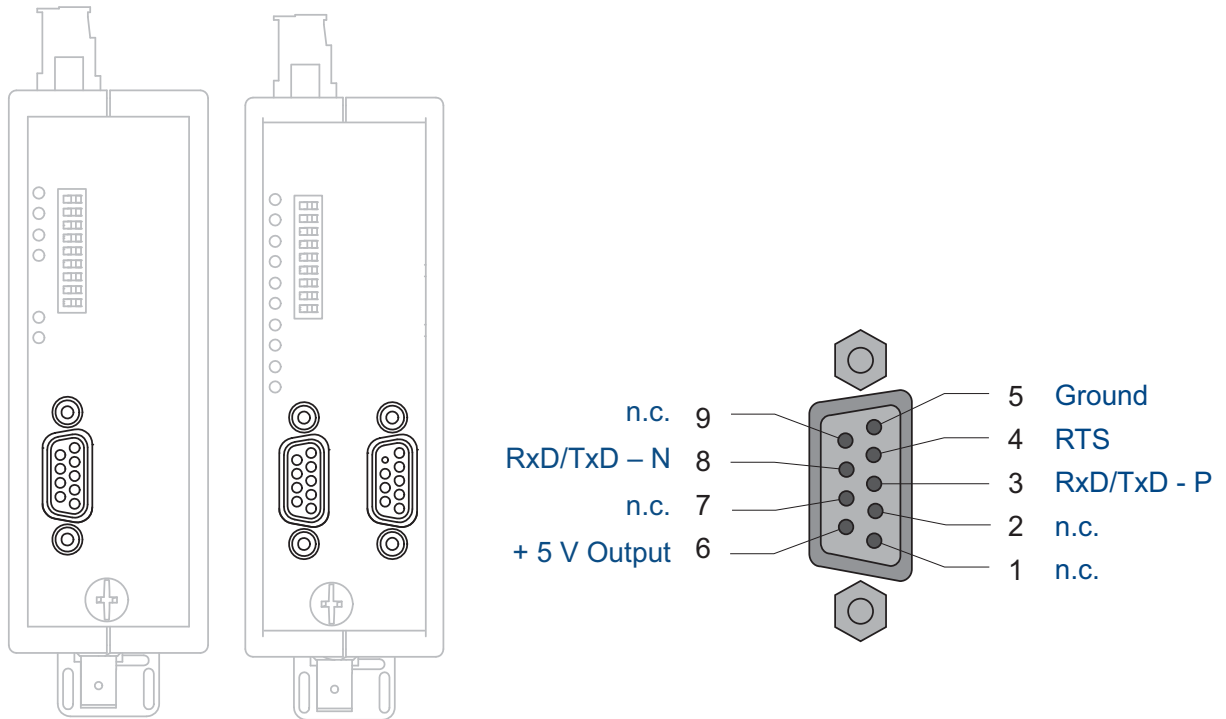

Figure 7: Pin assignment of D-Sub socket

- ▶ Depending on the device variant, the repeaters are fitted with one or two RS-485 electrical ports. This is a 9-pin D-Sub socket with a screw lock (inside thread UNC 4-40).
- ▶ The pin assignment complies with the PROFIBUS standard. At Pin 6 there is a short circuit-proof 5 V output for supplying external pull-up/pull-down resistors.
- ▶ As opposed to the 24 V power supply, the RS 485 bus lines RxD/TxD–N and RxD/TxD–P are indirect-coupled (functional separation) within SELV restrictions.
- ▶ The RS-485 interface is electrically connected to the front panel/function ground.
- ▶ Only use shielded and twisted-pair wiring as a RS-485 bus line.
- ▶ Use a PROFIBUS bus connector plug to connect the RS-485 bus segment.

**Note:**

- ▶ If the repeater is at the beginning or end of a bus segment, this connector must have an activated bus terminal resistor combination.
- ▶ Ensure that the bus segment connected to the RS-485 interface is terminated at both ends.
- ▶ Only use a connecting cable which is terminated at both ends to connect a single device.
- ▶ All PROFIBUS bus connector plugs in a network must be securely screwed onto the RS 485 interfaces.
- ▶ Attaching or removing the bus connector plugs, inadequately attached bus connector plugs or loose bus wires within the plug can lead to malfunctions in the optical and electrical networks.

**Perform the following work steps:**

- Attach or remove the RS 485 bus connector plug quickly and without twisting it.
- Remove the RS 485 bus line from the OZD Profi 12M... if a device is not connected to the other end, or there is an OZD Profi which has been disconnected from the power supply. The open line otherwise acts as an antenna and can cause interference.
- When connecting an RS 485 bus line to the OZD Profi 12M... in an active network, keep to the following sequence in order to avoid interference:
  - ▶ Place the RS 485 bus connector plug onto the device which is to be connected (e.g. to a programming device) and screw it on tightly.
  - ▶ Attach the RS 485 bus connector plug to the OZD Profi 12M... quickly and without twisting the connector, and screw it on tightly. Proceed in the reverse order when removing a device from the network.

Data rate	Range per segment
12 Mbit/s	328 ft (100 m)
6 Mbit/s	328 ft (100 m)
3 Mbit/s	328 ft (100 m)
1.5 Mbit/s	656 ft (200 m)
500 kBit/s	1312 ft (400 m)
187.5 kBit/s	3280 ft (1000 m)
93.75 kBit/s	3937 ft (1200 m)
45.45 kBit/s	3937 ft (1200 m)
19.2 kBit/s	3937 ft (1200 m)
9.6 kBit/s	3937 ft (1200 m)

Table 6: Range of RS-485 bus segment with cable type A

Properties of cable type A:

- ▶ Characteristic impedance: 135 - 165  $\Omega$
- ▶ Capacity coating:  $\leq 30$  pF/m
- ▶ Loop resistance:  $\leq 110$   $\Omega$ /km
- ▶ Wire diameter:  $> 0.64$  mm
- ▶ Wire cross section:  $> 0.34$  mm<sup>2</sup>

## 4.7 Connecting the function ground and the shield of the bus cable



### **WARNING**

There is no contact separation between the bus lines and the connection for the function ground.

Observe the following safety instructions:

- Do not use bus lines to connect repeaters to device parts which have a different earth potential. The different voltages could destroy the repeaters.
- Avoid electrical bus lines, which are partly or entirely laid outside buildings. If lightning strikes close by, this could destroy the repeaters. Use F/O cables for bus connections outside buildings.
- The shield of the bus cable, together with the function ground connection, must be connected to an equipotential rail in the switch cabinet. The equipotential rails of the switch cabinets, which are connected to one another by means of an electrical RS-485 bus cable, must have a low-impedance connection to one another.
- The function ground of the repeater is effected by means of the connection of the screw terminal block on front of the device.

## 4.8 Connecting the power supply

**Note:** To connect the lines for the power supply, remove the 8-pin terminal block on the top of the repeater from the device.

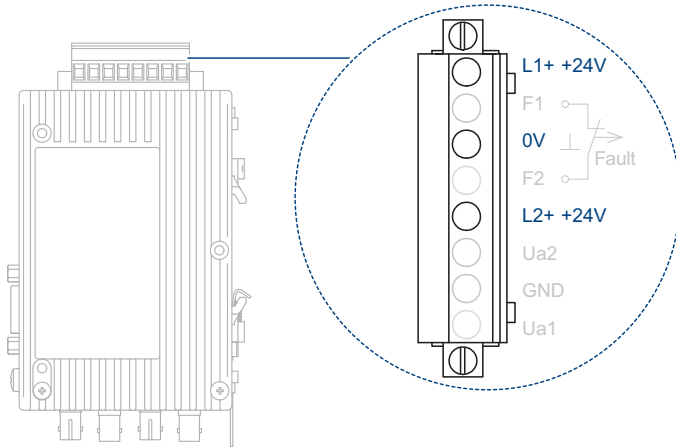

### Perform the following work steps:

- Only supply the OZD Profi 12M... with a stabilized safety extra-low voltage (SELV) in accordance with IEC 60950-1, 24 V DC maximum. It is supplied via the 8-pin terminal block on the top of the repeater.
- To improve the operating safety, a redundant power supply consisting of separate sources can be used. You can input the supply voltage in two ways:

Terminal +24 V DC (L1+)

Terminal +24 V DC (L2+)

The minus connection for each is indicated by "0 V".

- The two voltages can have any values, even different ones, within the specified limits.
- However, there is no load distribution. If necessary, the power supply unit with the higher output voltage must supply the power alone.

The supply voltage inputs are protected against incorrect pole connection.

The operating voltage is electrically isolated from the function ground

connection and from the other connections.



## 4.9 Connecting the signal contact (optional)

### Note:

- To connect the signal contact lines, remove the 8-pin screw terminal block on top of the repeater from the device.
- Use the correct pin assignment for the 8-pin terminal block.
- Make sure that the electrical insulation of the connection cables of the signal contacts is sufficient. Incorrect connections can destroy the repeater.

On the 8-pin terminal block on the top of the repeater, the unconnected pins of a relay can be used as signal contacts. When the OZD Profi 12M... is working correctly, the contact is closed. If there is an error or a power failure, the contact is opened.

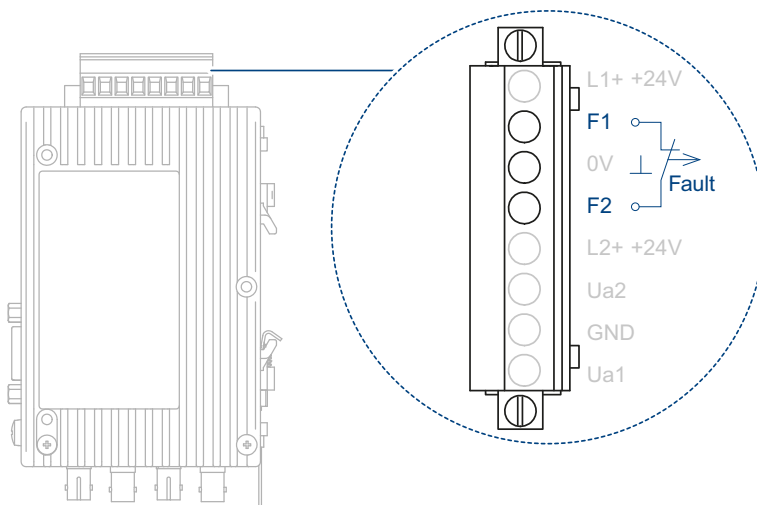

The following problems with the network and the repeater can be signaled by means of the signal contact:

<b>Supply voltage</b>	interrupted
	incorrectly connected
<b>Internal device errors</b>	
<b>Received data</b>	no input signal at port 3 (optical) (The numbering of the ports depends on device variant)
	no input signal at port 4 (optical) (The numbering of the ports depends on device variant)
	faults on port 1 (electrical) or port 2 (electrical)
<b>Redundant optical ring</b>	interruption of an optical fiber
	a repeater fails

## 4.10 Connecting the analog voltage outputs (optional)

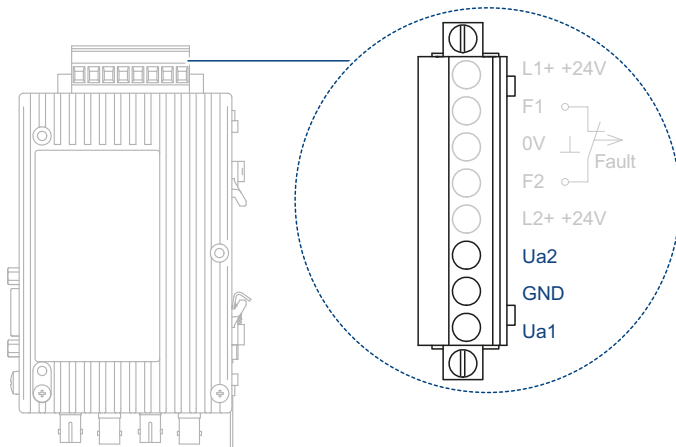

Figure 8: Pin assignment of the analog voltage outputs

The device has 2 analog voltage outputs, Ua1 and Ua2. These voltage outputs are connected using a 8-pin screw terminal on top of the repeater. The screw terminal is suitable for cable leads that have a cross section between 0.2 - 2.5 mm<sup>2</sup>.

The analog voltage outputs supply a short-circuit-proof output voltage dependent on the optical power input at port 2 or port 3, for diagnosis purposes and, for example, for preventative maintenance, in the range from 0 - 5 V (each with reference to “GND” of the 8-pin terminal block). The analog voltage outputs are electrically connected to the front panel/function ground.

The measuring voltage can be determined by a standard volt meter (ungrounded, high-impedance) . This allows the incoming optical power to be documented , e.g. for later measurements (aging, damage), a pass/fail examination to be performed (threshold value), wiring to be carried out on input terminals of a Profibus I/O module, thereby making the control system available. As with other process variables, it is possible to define warning thresholds there and use them for preventative maintenance.

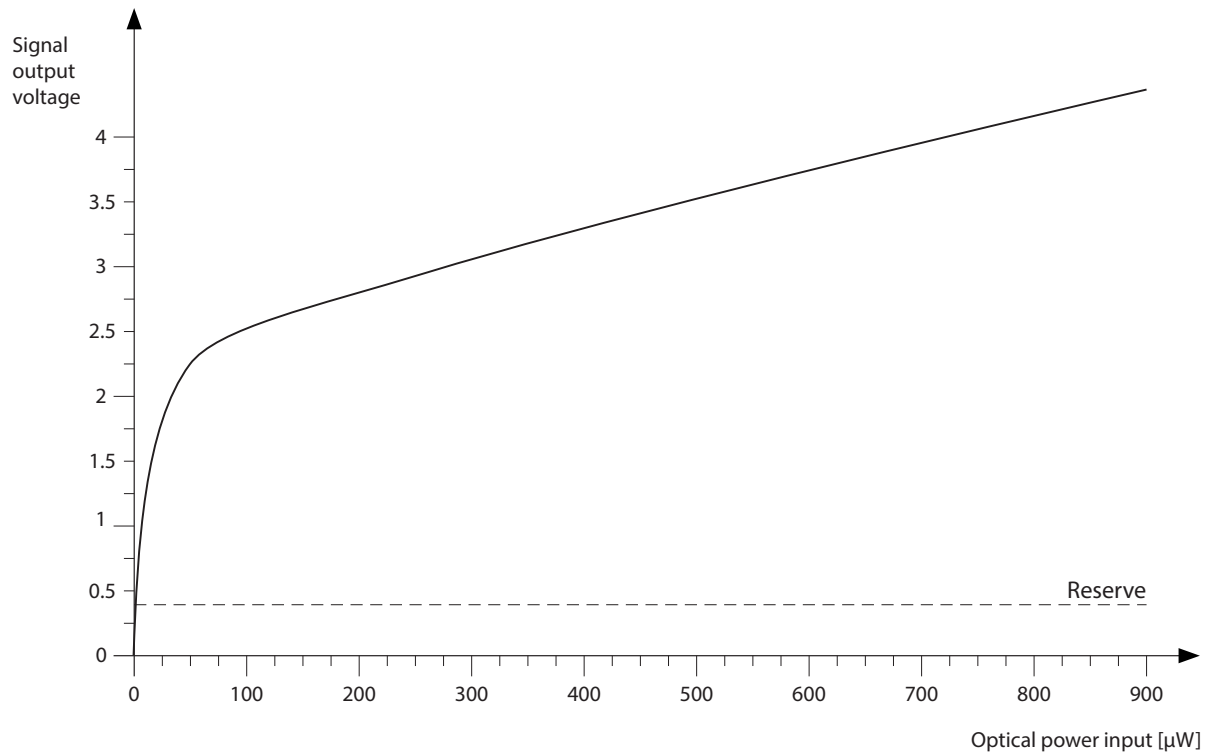

Figure 9: Correlation of measured output voltage to signal quality

**Note:** For a measured value to be valid, it is necessary that the partner OZD Profi 12M... on the other end of the optical fiber transmits regular PROFIBUS telegrams. An OZD Profi 12M... is no substitute for a calibrated, optical level meter. However, it provides each optical port with a voltage derived from the peak value of the optical PROFIBUS telegram without disrupting the communication of data. With regular bus operation, this analog voltage can be used as an indicator for an alteration in optical attenuation. Because data traffic and temperature can affect the voltage value, you should not set any warning threshold too close to the actual value.

# 5 Configuration

During configuration, the PROFIBUS network parameter "Slot time" must be adapted to the network coverage, network topology and the data rate due to frame delays caused by lines and network components, as well as by monitoring mechanisms in the network components.

■ Configuration of redundant optical rings

The following configuration conditions must be fulfilled in the redundant optical ring. See "Redundant ring" on page 36.

- ▶ (1) Configuration of a non-existent bus subscriber
- ▶ (2) Increasing the retry value to at least 3
- ▶ (3) Checking and adjusting the slot time

Use the user-specific profile of the configuration tool to set the parameters under (2) and (3).

Calculate the slot time with the following equation:

$$\text{Slot time} = a + (b \times \text{Length}_{\text{OF}}) + (c \times \text{Number}_{\text{OZD}})$$

Slot time	is the monitoring period in bit times.
Length <sub>OF</sub>	is the sum of all the optical fiber lines (segment lengths) in the network. The length must be given in km.
Number <sub>OZD</sub>	is the number of OZD Profi 12M... in the network.

Data rate	a	b	c
12 Mbit/s <sup>a</sup>	1651	240	28
6 Mbit/s <sup>a</sup>	951	120	24
3 Mbit/s <sup>a</sup>	551	60	24
1,5 Mbit/s <sup>a</sup>	351	30	24
500 kBit/s	251	10	24
187.5 kBit/s	171	3.75	24
93.75 kBit/s	171	1.875	24
45.45 kBit/s	851	0.909	24
19.2 kBit/s	171	0.384	24
9.6 kBit/s	171	0.192	24

Table 7: Constants for calculating the slot time at DP standard (redundant optical ring).

- a. Use the values from table 9 if the calculated slot time is smaller than the minimum slot time indicated in the table.

Data rate	a	b	c
12 Mbit/s <sup>a</sup>	1651	240	28
6 Mbit/s <sup>a</sup>	951	120	24

Table 8: Constants for calculating the slot time at DP/FMS ("universal") and DP with S595U (redundant optical ring)

Data rate	a	b	c
3 Mbit/s <sup>a</sup>	551	60	24
1.5 Mbit/s <sup>a</sup>	2011	30	24
500 kBit/s	771	10	24
187.5 kBit/s	771	3.75	24
93.75 kBit/s	451	1.875	24
45.45 kBit/s	851	0.909	24
19.2 kBit/s	181	0.384	24
9.6 kBit/s	171	0.192	24

*Table 8: Constants for calculating the slot time at DP/FMS ("universal") and DP with S595U (redundant optical ring)*

The calculation of the slot time only takes into consideration the optical network and the connection of bus subscribers to the OZD Profi 12M... via an RS 485 bus segment with a respective length of max. 20 m. Longer RS 485 bus segments must be allowed for by adding them to the Length OF.

**Note:** When the slot time is configured with a too small value the OZD Profi 12M... will, through it's fault function and fault indications, indicate such. The System-LED will blink red/green.

**Note:** Using the OZD Profi 12M G11-1300 and ... G12-1300 (EEC) at data rates of 12 MBit/s, 6 MBit/s, 3 MBit/s and 1.5 MBit/s the minimum slot times according to the following table must be met.

[See table 9 on page 61.](#)

Data rate	Minimum slot time
12 MBit/s	3800 t <sub>Bit</sub>
6 MBit/s	2000 t <sub>Bit</sub>
3 MBit/s	1000 t <sub>Bit</sub>
1.5 MBit/s	530 t <sub>Bit</sub>

*Table 9: Minimum slot time on OZD Profi 12M G11-1300 and OZD Profi 12M G12-1300 (EEC)*

## 6 Disassembly

To remove the device, pull down on the locking slide.

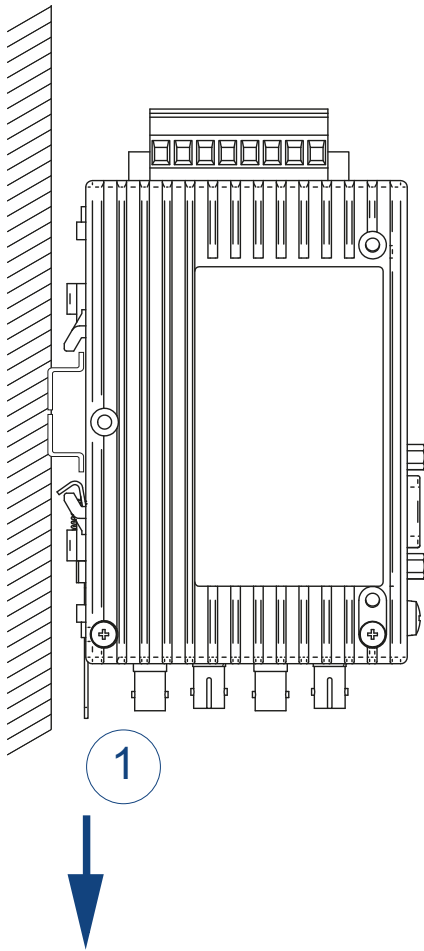

# 7 Technical data

## ■ General technical data

Device variant	OZD Profi...
Dimensions W × H × D	See “Dimension drawings” on page 67.
Weight	approx. 560 g (19.75 oz)
<b>Supply voltage</b>	
See “Requirements for connecting electrical wires” on page 8.	
Rated voltage	24 V DC
Voltage range incl. maximum tolerances	18 V DC ... 32 V DC
Connection type	8-pin terminal block
Power loss buffer	>10 ms at 20.4 V DC
Overload current protection on the device	Non-replaceable fuse
Back-up fuse for each voltage input	
Nominal rating:	2 A
Characteristic:	slow blow
Output voltage/current for terminal resistors (Pin 6 D-Sub socket)	5 V DC + 5 %, -10 %
Peak inrush current	<4 A
<b>Signal contact</b>	
See “Requirements for connecting electrical wires” on page 8.	
Maximum Switching current	1 A
Maximum switching voltage	60 V DC
Maximum switching capacity	max. 30 V DC, resistive load
<b>Signal transmission</b>	
Transmission speed	<ul style="list-style-type: none"><li>▶ 9.6 kBit/s</li><li>▶ 19.2 kBit/s</li><li>▶ 45.45 kBit/s</li><li>▶ 93.75 kBit/s</li><li>▶ 187.5 kBit/s</li><li>▶ 500 kBit/s</li><li>▶ 1.5 Mbit/s</li><li>▶ 3 Mbit/s</li><li>▶ 6 Mbit/s</li><li>▶ 12 Mbit/s</li></ul>
Setting transmission rate	automatic
Bit error rate	$< 10^{-9}$
Signal processing time (any input/output)	$\leq 6.5 t_{\text{Bit}}$
<b>Retimer</b>	
Input port 1 to 4	
▶ Signal distortion	$\pm 30\%$
▶ Mean bit length	$\pm 0.12 \%$
Output Port 1 to 4	
Mean bit length	$\pm 0.01 \%$

<b>Electrical ports</b>	
Isolation voltage	500 V DC
Input/output signal	RS 485 level
<b>Climatic conditions during operation</b>	
Ambient temperature	
▶ OZD Profi 12M... without "EEC" feature	0 °C ... +60 °C (+32 °F ... +140 °F)
▶ OZD Profi 12M... with feature "EEC" <sup>a</sup>	-25 °C ... +60 °C (-13 °F ... +140 °F)
Humidity	5 % ... 95 % (non-condensing)
Air pressure	min. 700 hPa (+3000 m ASL; +9842 ft ASL)
<b>Climatic conditions during storage</b>	
Ambient temperature	
-40 °C ... +70 °C (-40 °F ... +158 °F)	
Humidity	5 % ... 95 % (non-condensing)
Air pressure	min. 700 hPa (+3000 m ASL; +9842 ft ASL)
<b>Pollution degree</b>	2
<b>Protection classes</b>	Laser protection Class 1 in compliance with IEC 60825-1 Degree of protection IP20

- a. The devices OZD Profi 12M G12(-1300) and OZD Profi 12M G22(-1300) can also be supplied in a special design for more severe environmental conditions. These variants are designated OZD Profi 12M G12(-1300) EEC and OZD Profi 12M G22(-1300) EEC. For the variants OZD Profi 12M G12(-1300) EEC and OZD Profi 12M G22(-1300) EEC the DIP switches may only be operated at ambient temperatures between -20 °C ... +60 °C (-4 °F ... +140 °F).

<b>Optical port</b>	<b>P</b>	<b>G</b>	<b>G-1300</b>
Wavelength	<b>650 nm</b>	<b>860 nm</b>	<b>1300 nm</b>
<b>Launchable optical power</b>			
in fiber 10/125 (default)	-	-	-19 dBm
into fiber 50/125 (default)	-	-19 dBm	-17 dBm
in fiber 62.5/125 (default)	-	-13 dBm	-17 dBm
in fiber 200/230/125 (default)	-17 dBm	-	-
into fiber 200/230/125 (reduced)	-	13 dBm	-
in fiber 980/1000 (default)	-5 dBm	-	-
in fiber 980/1000 (reduced)	-10 dBm	-	-
Receiver sensitivity	-25 dBm	-28 dBm	-29 dBm
Receiver overload limit	0 dBm	-1 dBm	-3 dBm

<b>Damping values of the fiber optic</b>	<b>P</b>	<b>G</b>	<b>G-1300</b>
Wavelength	<b>650 nm</b>	<b>860 nm</b>	<b>1300 nm</b>
<b>Damping values</b>			
Fiber 10/125	-	-	0.5 dB/km
Fiber 50/125	-	3 dB/km	1 dB/km
Fiber 62.5/125	-	3.5 dB/km	1 dB/km
Fiber 200/230	10 dB/km	8 dB/km	-
Fiber 980/1000	0.225 dB/m	-	-



<b>Transmission distance<sup>a</sup></b>	<b>P</b>	<b>G</b>	<b>G-1300</b>
Wavelength	<b>650 nm</b>	<b>860 nm</b>	<b>1300 nm</b>
System reserve	2 dB	3 dB	2 dB
<b>Transmission distance</b>			
Fiber 10/125	-	-	49212.5 ft (15000 m)
Fiber 50/125 (default)	-	9842.5 ft (3000 m)	32808.4 ft (10000 m)
Fiber 62.5/125 (default)	-	9842.5 ft (3000 m)	32808.4 ft (10000 m)
Fiber 200/230/125 (default)	1312 ft (400 m)	-	-
Fiber 200/230/125 (reduced)	-	3280.8 ft (1000 m) for <12 MBit/s 2624.6 ft (800 m) for 12 MBit/s	-
Fiber 980/1000 (default)	262.4 ft (80 m)	-	-
Fiber 980/1000 (reduced)	187 ft (57 m)	-	-

- a. The specified distance allowed between two OZD Genius G12-1300 must not be exceeded regardless of the optical power budget.

## ■ EMC and immunity

<b>EMC interference emission</b>		
<b>Radiated emission</b>		
EN 55032		Class A
FCC 47 CFR Part 15		Class A
<b>EMC interference immunity</b>		
<b>Electrostatic discharge</b>		
EN 61000-4-2 IEEE C37.90.3	Contact discharge	±4 kV
EN 61000-4-2 IEEE C37.90.3	Air discharge	±8 kV
<b>Electromagnetic field</b>		
EN 61000-4-3	80 MHz ... 1000 MHz 1400 MHz ... 2000 MHz	max. 10 V/m
<b>Fast transients (burst)</b>		
EN 61000-4-4 IEEE C37.90.1	DC supply connection	±2 kV
EN 61000-4-4 IEEE C37.90.1	Data line	±1 kV
<b>Voltage surges - data line</b>		
EN 61000-4-5	line/ground	±1 kV
<b>Conducted disturbances</b>		
EN 61000-4-6	150 kHz ... 80 MHz	10 V

## ■ Power consumption/power output

<b>Device name</b>	<b>Maximum power consumption</b>	<b>Maximum power output</b>
OZD Profi 12M...	3.9 W (1 electrical port)	13.3 Btu (IT)/h
	4.7 W (2 electrical ports)	16 Btu (IT)/h

■ Dimension drawings

mm  
inch

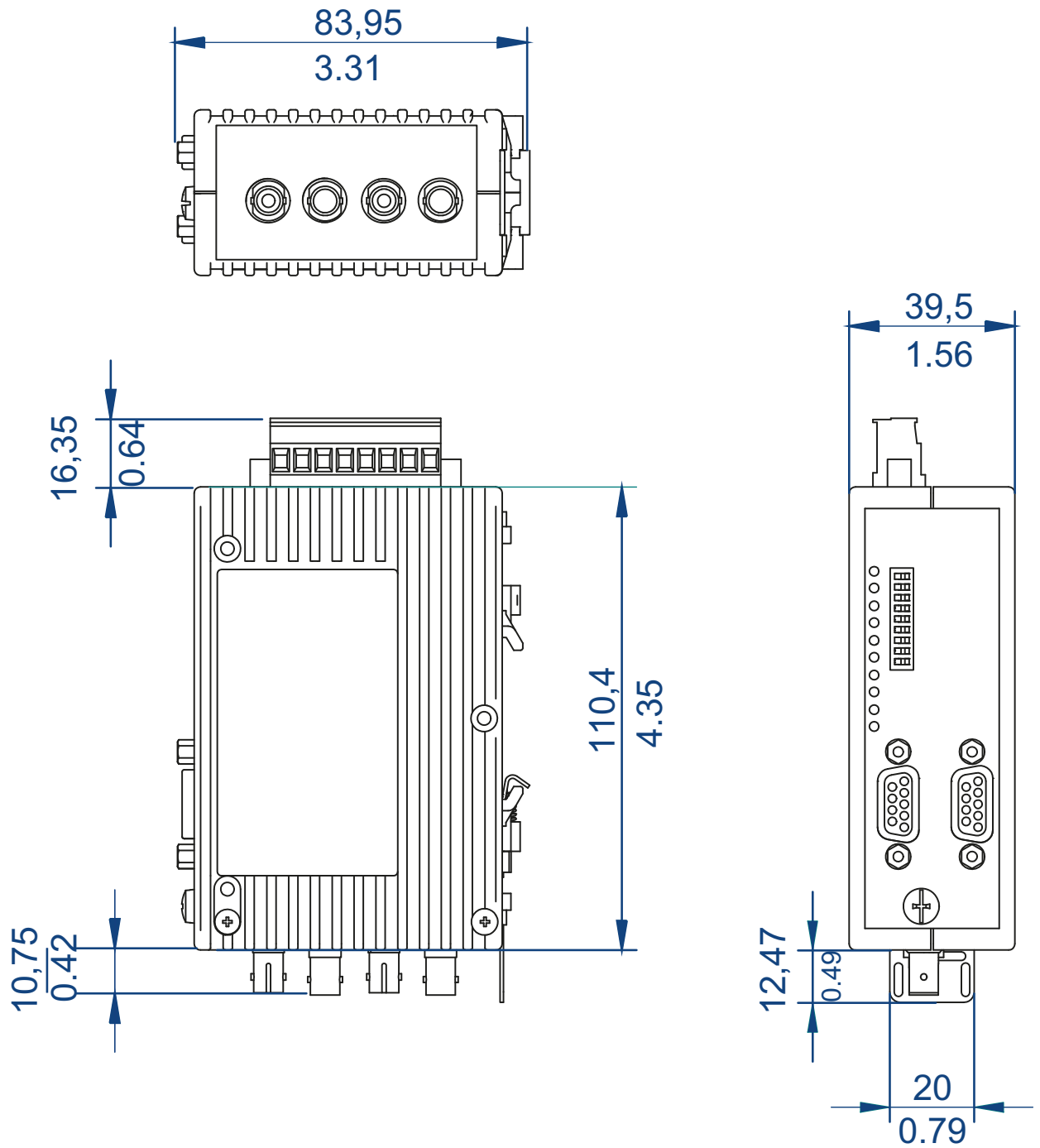

## 8 Scope of delivery, order numbers and accessories

### ■ Scope of delivery

Amount	Article
1 ×	Device
1 ×	Safety and general information sheet

### ■ Order numbers/product description

Device name	Order number
OZD Profi 12M G11	942 148-001
OZD Profi 12M G12	942 148-002
OZD Profi 12M G22	942 148-003
OZD Profi 12M G11-1300	942 148-004
OZD Profi 12M G12-1300	942 148-005
OZD Profi 12M G22-1300	942 148-006
OZD Profi 12M P11	942 148-007
OZD Profi 12M P12	942 148-008
OZD Profi 12M P22	942 148-009
OZD Profi 12M G12-EEC	942 148-102
OZD Profi 12M G12-1300-EEC	942 148-105
OZD Profi 12M G22-EEC	942 148-103
OZD Profi 12M G22-1300-EEC	942 148-106

## 9 Underlying technical standards

Name	
ANSI/UL 121201	Nonincendive Electrical Equipment for Use in Class I and II, Division 2 and Class III, Divisions 1 and 2 Hazardous (Classified) Locations
IEC/EN 60079-0	Explosive atmospheres – Part 0: Equipment – General requirements
EN 60079-7	Explosive atmospheres – Part 7: Equipment protection by increased safety “e”
IEC/EN 60079-15	Explosive atmospheres – Part 15: Equipment protection by type of protection “n”
CSA C22.2 No. 142	Canadian National Standard(s) – Process Control Equipment – Industrial Products
FCC 47 CFR Part 15	Code of Federal Regulations
UL 61010-1	Safety requirements for electrical equipment for measurement, control, and laboratory use - Part 1: General requirements
UL 61010-2-201	Safety requirements for electrical equipment for measurement, control, and laboratory use - Part 2-201: Particular requirements for control equipment
EN 55032	Electromagnetic compatibility of multimedia equipment – Emission Requirements
EN 61000-3-2	Electromagnetic compatibility (EMC) - Part 3-2: Limits - Limits for harmonic current emissions
EN 61000-3-3	Electromagnetic compatibility (EMC) - Part 3-3: Limits - Limitation of voltage changes, voltage fluctuations and flicker.
EN 61000-6-2	Electromagnetic compatibility (EMC) – Part 6-2: Generic standards – Immunity for industrial environments
EN 61000-6-4	Electromagnetic compatibility (EMC) – Part 6-4: Generic standards – Emitted interference in industrial environments
EN 61131-2	Programmable controllers – Part 2: Equipment requirements and tests

*Table 10: List of the technical standards*

The device has an approval based on a specific standard exclusively if the approval indicator appears on the device casing.  
The device generally fulfills the technical standards named in their current versions.

# 10 Help with problems

## 10.1 Troubleshooting

This chapter helps you to localize faults after they have been indicated (by LEDs or signal contacts).

- Fault indicated on the system LED  
For more details see chapter [“Display elements” on page 27](#).
  
- Fault indicated on CH1, CH2
  - Make sure that the DIP switch S0 is in position 1 if the OZD Profi connected to the electrical star segment of a star topology.  
[See “Star topology” on page 34](#).
  - Make sure that the fault is still displayed after removal of the RS 485 connector.  
Still displayed: Device is defective<sup>a, b</sup> Replace the OZD Profi.  
No longer displayed: The fault lies in the RS 485 bus segment.
    - ▶ Check all RS 485 connectors as described in “Connecting the electric bus cables”.  
[See “Connecting the electric bus cables” on page 53](#).
    - ▶ Check the structure and shielding of the RS 485 bus segment.
    - ▶ Check the RS 485 bus segment using a PROFIBUS bus monitor.
    - ▶ Check the configuration of all bus subscribers.

a. This is not the case if the monomaster of a PROFIBUS network is connected to the RS 485 bus segment which is to be examined.

b. Replace the OZD Profi concerned with another OZD Profi from the network, and then carry out the test described above.

If the OZD Profi still malfunctions when connected elsewhere, the device is defective. Replace the OZD Profi.

If the OZD Profi does not malfunction elsewhere, the fault lies in the RS 485 bus segment. Carry out the measures described above.

- Fault indicated on CH3, CH4
  - Make sure that optically only repeaters of the same type are connected together.  
See [“Network Topologies” on page 31.](#)
  - Make sure that the optical ports, which are connected via optical fibers, have been set to the same operating mode.  
See [“Setting the operating mode and transmitting power” on page 49.](#)
  - Make sure that the settings given in chapter “Connecting the optic bus cables“ have been observed when connecting and laying the optical bus lines.  
See [“Connecting the optic bus cables” on page 52.](#)

## 10.2 Systematic troubleshooting

This chapter helps you to localize an error systematically with the help of the following questions.

See also the description of the LED displays. See [“Display elements” on page 27.](#)

Check the following points:

- ▶ Are all the electrical bus lines terminated at both ends in accordance with PROFIBUS specification (even for short electrical lines)?
- ▶ Are the lengths of the optical cables within the threshold values specified in this manual?  
See [“Technical data” on page 63.](#)
- ▶ Is the reception level of the optical ports within the permissible range?
- ▶ Are the DIP switches set according to the topology, mode of operation, compatibility and optical transmission power?  
See [“Setting the operating mode and transmitting power” on page 49.](#)  
See [“Setting compatibility” on page 46.](#)

Were the following points taken into account regarding topology:

### Line topology

- ▶ Line topology selected and set according to the specifications in chapter “Line topology” with or without F/O link monitoring.  
See [“Line topology” on page 31.](#)

## Star topology

- ▶ CH1 must be switched to “Monitor off” mode (S0=1) for all OZD Profi 12M... connected to the electrical star segment.
- ▶ Wiring of the electrical star segment must be undertaken with care.
- ▶ Expansion of the electrical star segment is to be as small as possible.
- ▶ The electrical star segment must be terminated at both ends.
- ▶ No bus subscribers are to be connected to the electrical star segment.
- ▶ Non-busy optical ports are to be switched to “Line without F/O link monitoring” operating mode.

## Redundant optical ring

- ▶ Both ports of all the OZD Profi 12M ... must be set to “Redundant optical ring” operating mode.
- ▶ All the OZD Profi 12M... within a ring must be optically linked with one another.

**Note:** Configuration (these settings can usually be set on the PROFIBUS master using configuration software, not on the OZD Profi 12M... ):

- Slot time configured correctly? (for basics, [See “Redundant ring” on page 36.](#), for calculation, see “TSLOT.exe”)
- Retry value configured correctly? (target value  $\geq 3$ , [See “Redundant ring” on page 36.](#))
- Value of MIN  $T_{SDR}$  configured correctly? (target value  $\geq 11$ , see chapter [“Line topology” on page 31](#))
- In case of redundant optical ring only: “HSA” (Highest Station Address) configured correctly or “a non-existent bus subscriber” configured? It may be necessary to perform a reset on the device on which the parameters were changed (e.g. master) so that the new values are also transferred.

**Note:** Check the status of the LEDs. Check by chapter [“Display elements” on page 27](#) and [“Troubleshooting” on page 70](#) the possible causes and resolve the errors detected.



## 10.3 Problem reporting

If the transmission in the RS 485 network is still not satisfactory after all the points in the chapters [“Display elements” on page 27](#) and [“Troubleshooting” on page 70](#) have been clarified, then please contact our support with answers to the following questions:

- ▶ Exact type designation of the OZD Profi 12M... . For identification purposes, please provide the order number printed on the device (18 digits).
- ▶ What data rate is being used?
- ▶ How are the DIP switches set on all the devices?
- ▶ Send us a detailed network plan with the fiber type and fiber length, the location and length of the electrical segments and the position of the terminators.
- ▶ Give as detailed a description of the error as possible in your own words.
- ▶ Which values were configured for slot time, retry value and MIN  $T_{SDR}$ ?
- ▶ What is the status of the LEDs on the relevant OZD Profi 12M... ?
- ▶ Please provide the voltage values of the analog voltage outputs for the relevant OZD Profi 12M... .  
[See “Connecting the analog voltage outputs \(optional\)” on page 58.](#)
- ▶ In case of redundant optical ring only: Which value was configured for HSA (Highest Station Address)? Was a non-existent bus subscriber configured?

**Note:** If you do not provide complete answers to the questions, we cannot process your query.

# A Further support

## Technical questions

For technical questions, please contact any Hirschmann dealer in your area or Hirschmann directly.

You find the addresses of our partners on the Internet at <http://www.hirschmann.com>.

A list of local telephone numbers and email addresses for technical support directly from Hirschmann is available at <https://hirschmann-support.belden.com>.

This site also includes a free of charge knowledge base and a software download section.

## Customer Innovation Center

The Customer Innovation Center is ahead of its competitors on three counts with its complete range of innovative services:

- ▶ Consulting incorporates comprehensive technical advice, from system evaluation through network planning to project planning.
- ▶ Training offers you an introduction to the basics, product briefing and user training with certification.  
You find the training courses on technology and products currently available at <https://www.belden.com/solutions/customer-innovation-center>.
- ▶ Support ranges from the first installation through the standby service to maintenance concepts.

With the Customer Innovation Center, you decide against making any compromises in any case. Our client-customized package leaves you free to choose the service components you want to use.

Internet:

<https://www.belden.com/solutions/customer-innovation-center>





**HIRSCHMANN**

---

A **BELDEN** BRAND