

Manual

Universal RS 485 Fiberoptic Repeater OZD 485 G12 BAS

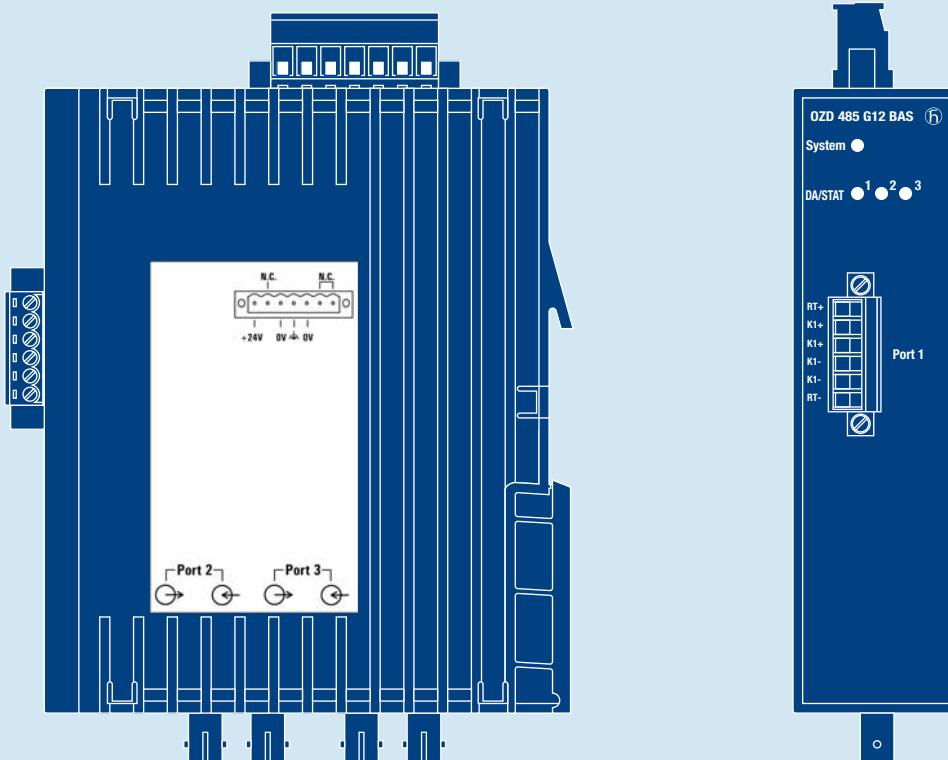

Order Numbers

OZD 485 G12 BAS	943 893-321
Manual Universal RS 485 Fiberoptic Repeater OZD 485 G12 BAS	039 554-001

The performance features described here are binding only if they have been expressly agreed when the contract was made. We have checked the content of this document for consistency with the hardware and software it describes. However, inconsistencies cannot be ruled out, and thus we cannot guarantee absolute consistency. Nevertheless, the information in the document is checked regularly. Necessary corrections are contained in the following printings. We are grateful for any suggested improvements.

Technical modifications reserved.

This document may not be passed on, copied, nor may its contents be used or distributed, unless expressly permitted. Violators will be held liable for compensation. All rights are reserved, particularly if a patent is granted or the design is registered.

© Hirschmann Automation and Control GmbH

All Rights Reserved

Note

We wish to point out that the content of this manual is not part of a previous or existing agreement, consent, or legal relationship, or shall not amend same. All the liabilities of Hirschmann result from the respective sales contract, which also contains the complete and solely valid guarantee regulations. These contractual guarantee specifications are neither enhanced nor restricted by the information in this manual.

We also wish to point out that for reasons of comprehensibility, not every conceivable problem relating to the use of this device can be described in this manual. Should you require further information, or should particular problems occur which are not dealt with in sufficient detail in this manual, you can request the required information from your local Hirschmann dealer or directly from Hirschmann (for address, see section "Note on CE Marking").

Notes on safety

This manual contains instructions to be observed for ensuring your personal safety and for preventing damage. The warnings appear next to a warning triangle with a different heading depending on the degree of danger posed:



Danger!

Means that death, serious physical injury or considerable damage to equipment **will** occur if the required precautionary measures are not taken.



Warning!

Means that death, serious physical injury or considerable damage to equipment **can** occur if the required precautionary measures are not taken.



Caution!

Means that minor physical injury or damage to equipment can occur if the required precautionary measures are not taken.

Note:

Contains important information on the product, on how to manage the product, or on the respective section of the documentation to which your particular attention is being drawn.

Qualification requirements for personnel

Note:

Qualified personnel as understood in this manual and the warning signs, are persons who are familiar with the setup, assembly, startup, and operation of this product and are appropriately qualified for their job. This includes, for example, those persons who have been:

- trained or instructed or authorized to switch on and off, to ground and to label power circuits and devices or systems in accordance with current safety engineering standards;
- trained or instructed in the care and use of appropriate safety equipment in accordance with the current standards of safety engineering;
- trained in providing first aid.

General safety instructions

- ▶ This device is operated by electricity. You must follow precisely the prescribed safety requirements in the operating manual that relate to the voltage connections!
- ▶ Make sure that the electrical installation meets local or national safety regulations.



Warning!

Non-observance of these safety instructions can cause material damage and/or serious injuries. Only appropriately qualified personnel should work on this device or in its vicinity. This personnel must be thoroughly familiar with all the warnings and maintenance procedures in accordance with this operating manual.

The proper and safe operation of this device depends on proper handling during transport, proper storage and assembly, and conscientious operation and maintenance procedures. Never start operation with damaged components.



Warning!

Any work that may be required on the electrical installation may only be carried out by personnel trained for this purpose.



Warning!

LASER CLASS 1 in compliance with IEC 60825-1 (2001).

Correct operation

Please note the following:



Warning!

The device may only be used for those purposes specified in the catalog and in the technical description, and only in combination with external devices and components approved by Hirschmann. The proper and safe operation of this product depends on proper handling during transport, proper storage and assembly, and conscientious operation and maintenance procedures.

Safety instructions for supply voltage

- ▶ Only switch on the device when the housing is closed.



Warning!

The devices may only be connected to the supply voltage shown on the type plate. The devices are designed for operation with safety extra-low voltage. Accordingly, only PELV circuits or SELV circuits with voltage restrictions in line with IEC/EN 60950 may be connected to the supply voltage connections and the signal contact.

- ▶ If you are operating the module with an external voltage: Only supply the system with a low safety voltage in compliance with IEC/EN 60950.

Relevant for North America:

- ▶ The device may only be connected to a supply voltage of class 2 that fulfils the requirements of the National Electrical Code, Table 11(b). If the voltage is being supplied redundantly (two different voltage sources), the combined supply voltages must fulfil the requirements of the National Electrical Code, Table 11(b).
- ▶ Only use copper wire/conductors of class 60/75°C or 75°C.

Safety instructions for environment



Warning!

The device may only be operated in the specified ambient temperature and relative air humidity (non-condensing).

- ▶ Select the installation site so that the climatic threshold values specified in the technical data are adhered to.
- ▶ Only to be used in an environment with contamination level 2 (IEC 60664-1).

Safety instructions for housing



Warning!

Only technicians authorized by Hirschmann are permitted to open the housing.

Underlying norms and standards

The devices fulfill the following norms and standards:

- EN 61000-6-2:2001 Generic standards – Immunity for industrial environments
- EN 55022:1998 + A1 2000+A2:2003 – Information technology equipment – Radio disturbance characteristics
- EN 61131-2: Programmable controllers
- EN 60825-1 Safety of laser products
- FCC 47 CFR Part 15:2004 – Code of Federal Regulations

Note on the CE marking



The devices comply with the regulations of the following European directives:

89/336/EEC

Council Directive on the harmonization of the legal regulations of member states on electromagnetic compatibility (amended by Directives 91/263/EEC, 92/31/EEC and 93/68/EEC).

The precondition for compliance with EMC limit values is strict adherence to the installation guidelines specified in this description and operating instructions.

The EU declaration of conformity is kept available for the responsible authorities in accordance with the above-mentioned EU directives at:

Hirschmann Automation and Control GmbH
Abteilung AM
Stuttgarter Strasse 45-51
72654 Neckartenzlingen
Telefon 01805/14-1538
E-Mail hac-support@hirschmann.de

The product can be used in the residential sphere (residential sphere, business and trade sphere and small companies) and in the industrial sphere.

- Interference immunity:
EN 61000-6-2:2001
- Interference emissions:
EN 55022:1998+A1:2000+A2:2003 Class A



Warning!

This is a Class A device. This equipment may cause radio interference if used in a residential area; in this case it is the operator's responsibility to take appropriate measures.

FCC RULES

This device complies with part 15 of the FCC Rules. Operation is subject to the following two conditions:

- (1) This device may not cause harmful interference, and
- (2) This device must accept any interference received, including interference that may cause undesired operation.

Note: This equipment has been tested and found to comply with the limits for a Class A digital device, pursuant to part 15 of the FCC Rules. These limits are designed to provide reasonable protection against harmful interference when the equipment is operated in a commercial environment. This equipment generates, uses, and can radiate radio frequency energy and, if not installed and used in accordance with the instruction manual, may cause harmful interference to radio communications. Operation of this equipment in a residential area is likely to cause harmful interference in which case the user will be required to correct the interference at his own expense.

Recycling note



After usage, this product must be disposed of properly as electronic waste in accordance with the current disposal regulations of your county/state/country.

C-Tick

Australia / New Zealand



This product meets the requirements of the AS/NZS 3548 standard.

N13320

Certifications

Note:

Only the certifications indicated on the label attached to each device are applicable.

Relevant information for North America:

- ▶ Only for connection with a Class 2 power supply.
- ▶ For use in Class 2 Circuits.
- ▶ Use 60/75 or 75 °C copper(CU)wire only.

Contents

1 Introduction	7
2 Half duplex operation	9
3 Tristate recognition through permanent high	11
4 Network topologies	13
4.1 Line topology without redundancy	13
4.2 Star distributor	14
4.3 Network range	15
4.4 Cascadability and data rate	15
5 Installation	17
5.1 Installation guidelines	17
5.2 Use in North America	19
5.3 Installing procedure	19
5.4 Installing repeater	20
5.5 Installing terminating resistor and pull-up/pull-down resistors	21
5.6 Connecting the optic bus cables	21
5.7 Connecting the electric bus cables	22
5.8 Connecting the function ground	22
5.9 Connecting the operating voltage supply	23
5.10 Checking the LED indicators	23
6 Bus configurations	25
6.1 BITBUS	25
6.2 Configuration of other bus systems	26
7 Help with problems	27
7.1 LED displays	27
7.2 Troubleshooting	28
7.3 Problem reporting	28
7.4 Contact address	29
8 Technical data	31

1 Introduction

The RS 485 Fiberoptic Repeater OZD 485 G12 BAS is intended for use in optical RS 485 fieldbus networks such as PROFIBUS, BITBUS and company-specific busses.

It enables you to convert electrical RS 485 signals to optical ones, and the reverse.

With the OZD 485 G12 BAS Repeaters, you can construct universal half (2-wire) duplex transmission systems with RS 485 interfaces.

You can integrate the Repeaters into existing electrical RS 485 fieldbus networks. You can also build up a complete optical RS 485 fieldbus network in line or star topologies with OZD 485 G12 BAS Repeaters.

The housing consists of two plastic sections and a front panel made of metal. It can be mounted on a DIN rail.

Ports

The Repeater has three independent ports, which in turn consist of a transmitter and a receiver component. Port 1 is a 6-pin screw terminal block, and ports 2 and 3 are optical BFOC/2.5 (ST[®]) sockets.

Power supply

The power supply is +18 VDC to +32 VDC (typ. +24 VDC) direct current.

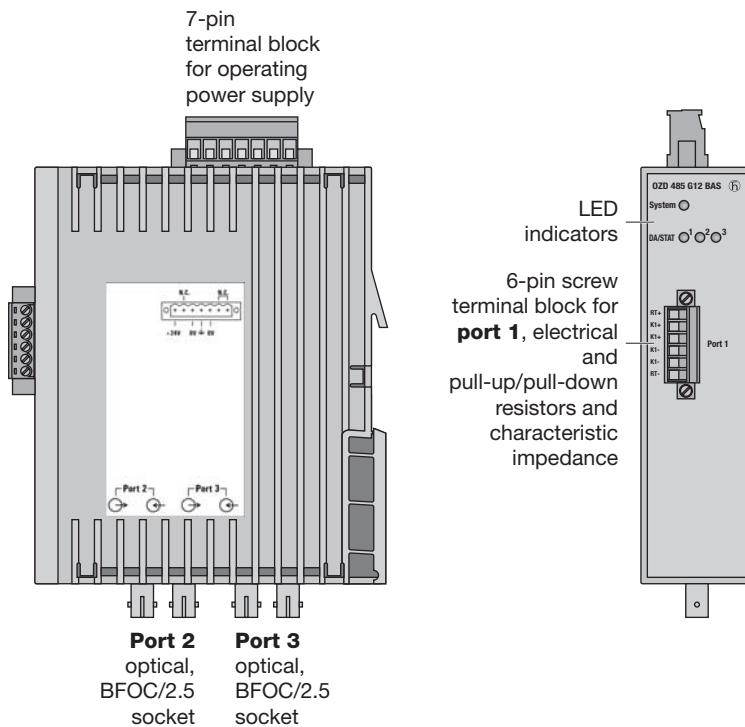

Fig. 1: Fiberoptic Repeater OZD 485 G12 BAS with location of individual ports, terminal blocks and LED displays

LEDs

Four one- and two-colored light-emitting diodes signal the current operating status and any possible operating errors.

Glass fiber technology

The use of glass fiber transmission technology enables a very large transmission range and ensures optimal protection from EMC effects on the transmission path and – due to the potential separation – on the Repeater itself.

Transmission speed

The RS 485 Fiberoptic Repeater OZD 485 G12 BAS supports all data rates from 0 to 1.5 MBit/s NRZ.

Network range

The permissible network range for the line or star topology depends on the bus system and terminal devices used. See chapter 4.3, page 15.

Compatibility with other RS 485 Fiberoptic Repeaters

The **OZD 485 G12 BAS** may be operated via the optical ports in conjunction with the RS 485 Fiberoptic Repeaters OZD 485 G12 PRO and OZD 485 G12 as long as only those properties that are also supported by the OZD 485 G12 BAS are used in the entire network.

2 Half-duplex operation

The data channel of the electrical port (Port 1) can transmit data in half-duplex mode. It replaces a 2-wire cable. In half-duplex mode, the arbitration procedure used by the connected devices must ensure that at any given time, only one device can access the bus, like in master/slave operation. Access procedures where there is a risk of collisions, such as CAN, are not permissible.

In half-duplex mode, consecutive data telegrams must be separated by a minimal time gap of $3.5 \mu\text{s}$ so that the end of a data telegram can be definitively recognized and thus the data direction can be switched in the OZD 485 G12 BAS.

You can cascade a number of OZD 485 G12 BAS via the optical interfaces. Devices or bus segments may be connected to the electrical interfaces of all the cascaded OZD 485.

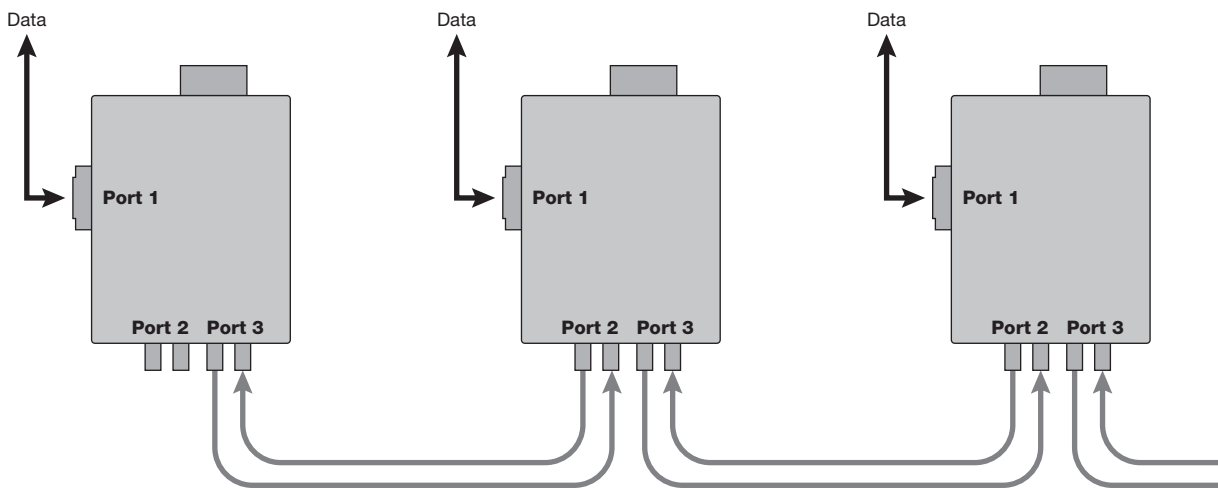

Fig. 2: Half-duplex mode

3 Tristate recognition through permanent high

One 2-wire lead, terminated by a characteristic impedance and additional pull-up/pull-down resistors, is replaced (e.g. PROFIBUS).

During the idle phase, a logical high level (positive voltage between terminals K1+ and K1-) is available. As soon as a constant high level is available for 2.5 μ s, the

repeaters identify this as tristate and switch their transmitters to the idle state (transmitter set to high-resistance).

A downward slope is identified as the start bit. Transmission is made in the appropriate direction. The opposite direction is disabled.

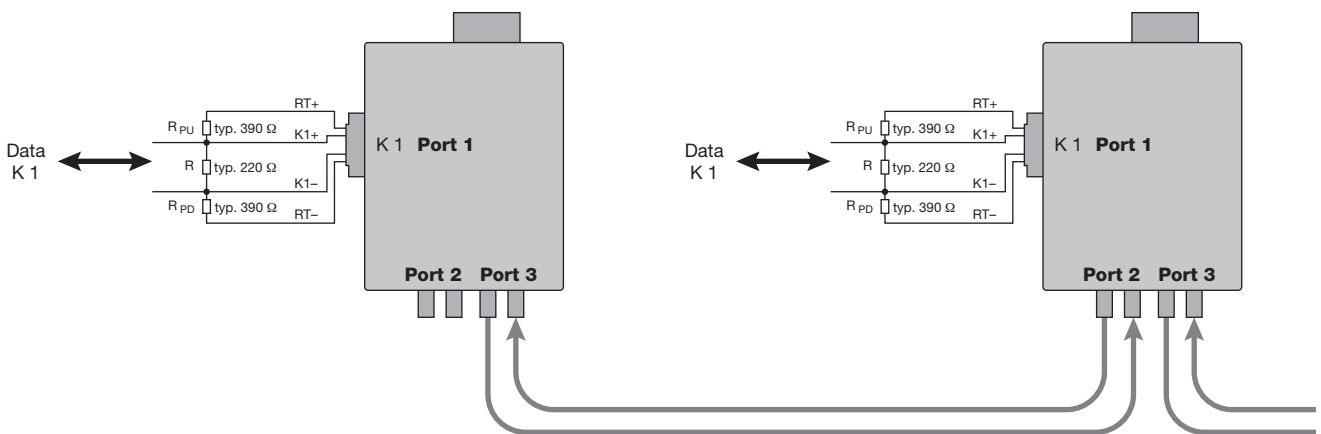

Fig. 3: Tristate recognition through permanent high

4 Network topologies

4.1 Line topology without redundancy

This network topology can be used for an optical connection of end devices or bus segments.

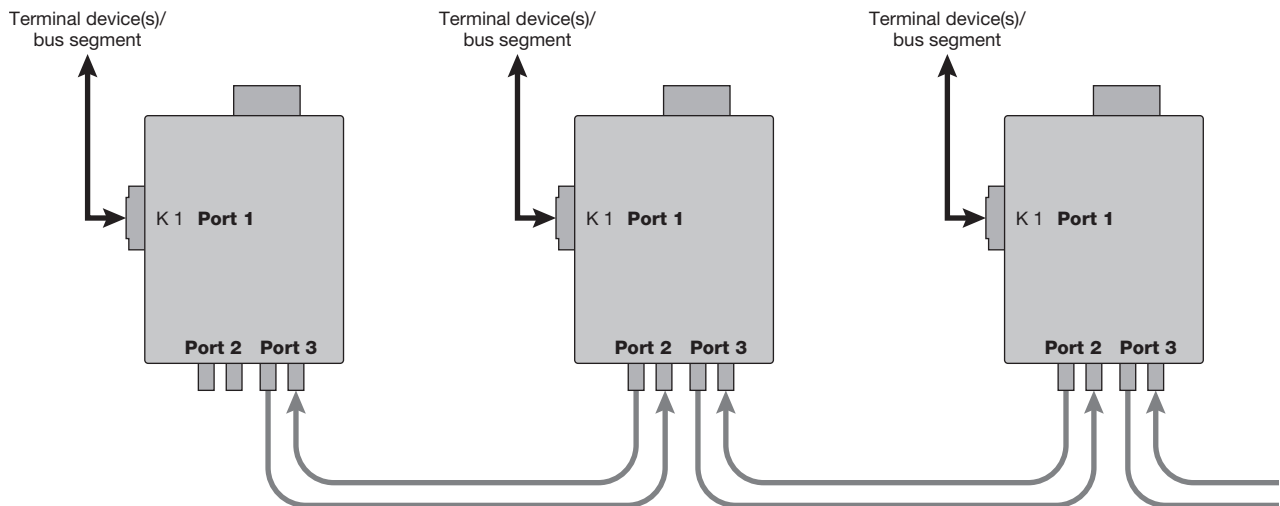

Fig. 4: Line topology without redundancy

4.2 Star distributor

The star distributor is made by coupling two or more OZD 485 G12 BAS via the electrical interfaces. Lines or other star distributors can be connected to the optical interfaces of the coupled repeaters. The termination at the start and end of the star point lead

must have the same resistance values as the termination of the bus.

The star distributor can be used to create bridges between single-mode and multi-mode fiber links.

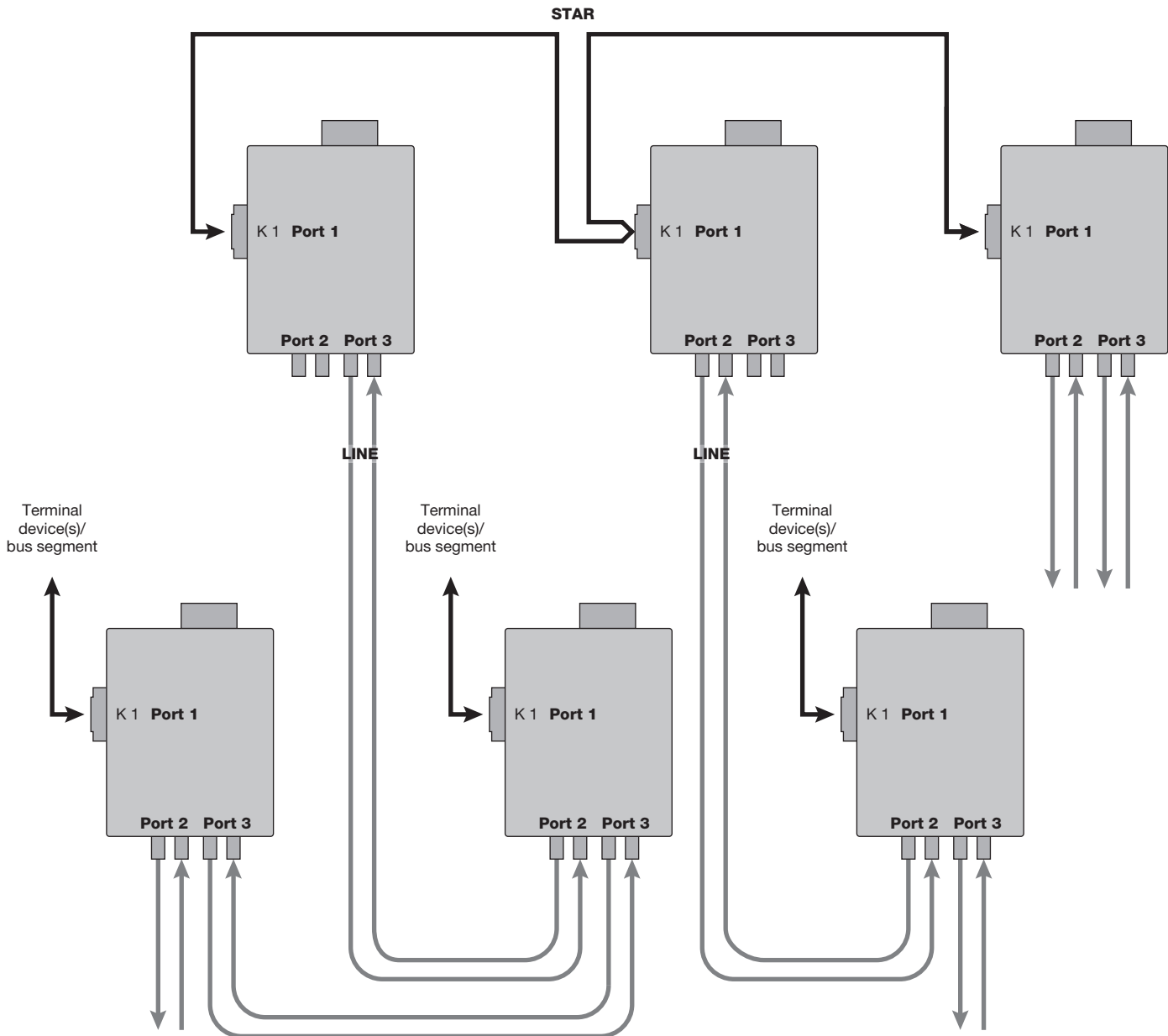

Fig. 5: Star distributor

4.3 Network range

The maximum network range depends on the permissible signal processing times of the bus system and terminal devices used.

The signal processing time for the planned network t_N is made up of the signal processing times from the electrical leads (approx. 5 $\mu\text{s}/\text{km}$) and the optical fibers (approx. 5 $\mu\text{s}/\text{km}$) and the signal processing times in the repeaters OZD 485 G12 BAS (max. 1.33 $\mu\text{s}/\text{repeater}$).

In the **line structure**, t_N is equal to the total processing time between the two ends of the line.

In the **star structure**, t_N is equal to the longest processing time in the network.

4.4 Cascadability and data rate

The cascadability depends on how big the permissible bit duration distortion of the bus system used or the terminal devices is.

The increase in the bit duration distortion due to jitter in the optical transmission link depends on the number of OZD 485 G12 BAS in the transmission link.

Determining the cascadability

To determine the maximum cascadability in a planned network, you must know the following:

- Maximum permissible bit duration distortion in the bus system or terminal devices used
- Transmission rate

Example

The permissible bit duration distortion in the end devices is 20%, for example. If the transmission rate is 1 Mbit/s, then a bit that is nominally 1 μs long may be lengthened or shortened by 200 ns.

The increase in jitter for each OZD 485 G12 BAS is 10 ns. The result of this is that there may be up to 20 OZD 485 G12 BAS in the transmission link (see fig. 6).

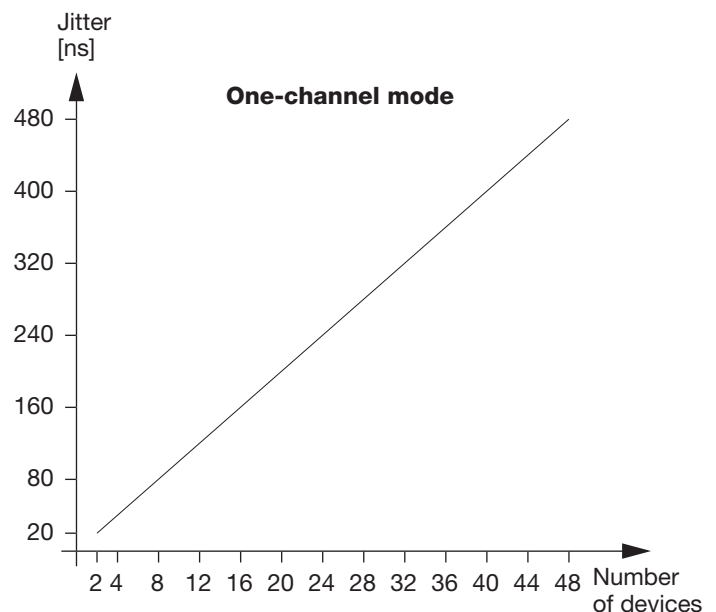

Fig. 6: Relationship between number of devices and jitter

5 Installation

5.1 Installation guidelines

Electromagnetic compatibility (EMC)

Electromagnetic compatibility (EMC) covers all aspects regarding the effects of radiated and received electrical, magnetic and electromagnetic emissions.

In order to prevent interference in electrical systems, these effects must be reduced to a minimum.

The structural design and correct connection of bus lines as well as the interference suppression of switched inductances play a major role in limiting interference.

Interference suppression of switched inductances

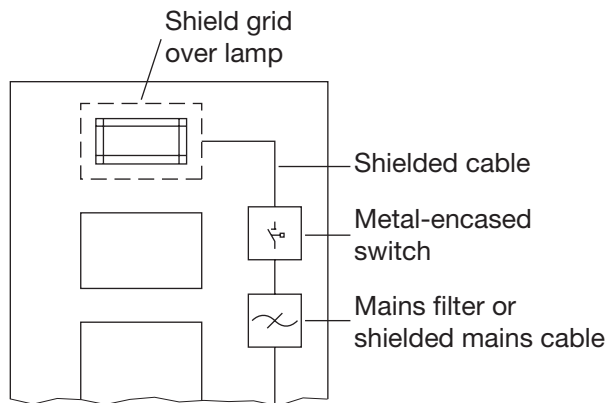

Fig. 7: Interference suppression of fluorescent lamps in cabinet

- ▶ Suppressing switched inductances with fuses
Switching inductances, e.g. in relays and fans, generates interference voltages which are many times higher than the switched operating voltages. These interference voltages might affect electronic appliances. The interference voltages of inductances must be limited at their source of emission by means of fuses (by connecting diodes or RC elements). Only use interference suppressors which are intended for the relays and fans used.
- ▶ Cabinet lighting
Use filament lamps (e.g. LINESTRA lamps) for the cabinet lighting. Do not use fluorescent lamps because they generate interference fields. If the use of fluorescent lamps cannot be avoided, the interference suppression measures shown in Fig. 7 must be implemented.

Arrangement of devices and cables

- ▶ Reducing interference by providing adequate space
A simple yet effective way of reducing interference is to separate devices and cables causing interference from those affected by interference. Inductive and capacitive interference injection decreases by the square of the distance between the elements concerned. This means that doubling the distance reduces the interference by a factor of 4. If the arrangement of the various elements in a building or in the switch cabinet is taken into consideration at the planning stage, the cost of the necessary interference suppression measures is generally very low.
- ▶ Please note:
Between an OZD 485 G12 BAS and a power switching element (e.g. contractor, relay, temperature regulator, switch, etc.) a minimum separation of 15 cm is to be maintained. This minimum is to be measured between the outer edges of the components and in all directions around an OZD 485 G12 BAS.

The power supply wires (+24 VDC and 0 V) for the OZD 485 G12 BAS must not be laid in the same cable duct as cables for load circuits.

The wires (+24 VDC and 0 V) should be twisted together.

- ▶ Standard recommendations for the arrangement of devices and cables
EN 50174-2 contains recommendations for arranging devices and cables which are aimed at reducing mutual interference to a minimum.
- ▶ Using bus line shields
It is important to observe the following when shielding bus lines:
 - Only use fully shielded lines. The shields of these lines must be of sufficient thickness to satisfy the legal requirements for interference radiated and interference received.

- Always attach the shields at both ends of the bus lines. The legal requirements regarding interference radiated and interference received for your system will only be satisfied if shields are connected at both ends (CE symbol).
- Dismantle the shield of the bus cable completely and put it on an equipotential rail. This rail must in turn be connected with the function ground of the OZD 485 G12 BAS by means of a short cable.

Note:

If differences in potential occur between the grounding points, an inadmissably high compensating current could flow across the shielding connected at both ends. Never eliminate this problem by removing the shielding from the bus line!

The following solution is permissible:

Lay an additional equipotential bonding cable parallel to the bus line.

Shield connections

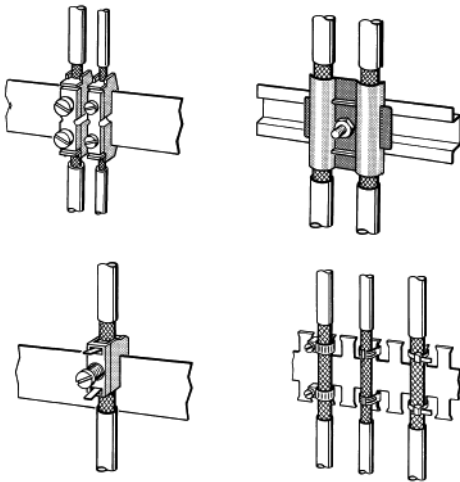

Fig. 8: Securing shielded lines using cable clamps and tube clips (schematic diagram)

Always observe the following points when installing bus line shielding:

- ▶ Secure the shield braid using metal cable clamps.
- ▶ The clamps must fully enclose the shield and make good contact (see Fig. 8).
- ▶ Only contact the lines via the copper braid shield.
- ▶ The shields of all cables which are routed into a cabinet from the outside must be clamped at the point of entry inside the cabinet and connected to the cabinet ground with a large contact surface area.
- ▶ When removing the cable jackets, it is important to ensure that the braid shield of the cables is not damaged. Tin-plated or galvanically stabilized surfaces are ideal for optimum contacting between grounding elements. With zinc-plated surfaces, suitable threaded connections must be provided for the required contacts. Painted surfaces at the contact points are unsuitable.
- ▶ Shield clamps/contact points should not be used as strain relief devices. Contact with the shield bus could otherwise deteriorate or break completely.

5.2 Use in North America

Relevant information for North America:

- ▶ Only for connection with a Class 2 power supply.
- ▶ For use in Class 2 Circuits.
- ▶ Use 60/75 or 75 °C copper(CU)wire only.

5.3 Installation procedure

The RS 485 Fiberoptic Repeater OZD 485 G12 BAS is installed by the following steps:

- ▶ Installing repeater
- ▶ Installing terminating resistors and (as long as the device is located at the end of the line)
- ▶ If necessary: Install pull-up/pull-down resistors (as long as the device is located at the end of the line)
- ▶ Connecting the optical bus cables
- ▶ Connecting the electrical bus cables
- ▶ Connecting the function ground
- ▶ Connecting the operating voltage supply
- ▶ Checking the LED indicators

5.4 Installing repeater

The Fiberoptic Repeater OZD 485 G12 BAS can be mounted on a 35 mm DIN rail in accordance with IEC 60715: 1981 + A1: 1995.

- ▶ Install the device in a location where the climatic threshold values specified in the technical data are adhered to.
- ▶ Ensure that there is sufficient room to connect the bus and power supply cabling.
- ▶ Connect the optical fiber line before mounting the repeater as this simplifies the procedure.
- ▶ Mount the repeater on the DIN rail.
To do this, hang the top latch of the repeater into the DIN rail and press the underside onto the rail - as shown in Fig. 9 - until the latch clicks in.

Note:

You can remove the repeater from the DIN rail by unlocking the snap lock with a screwdriver, as shown in Fig. 10.

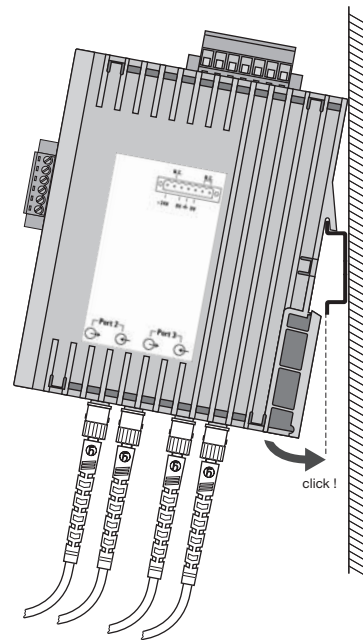

Fig. 9: Mounting a repeater on a DIN rail

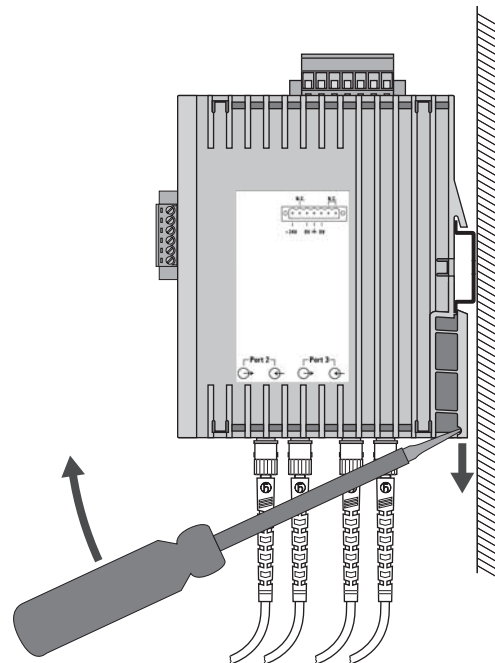

Fig. 10: Removing the repeater from a DIN rail

5.5 Installing terminating resistor and pull-up/pull-down resistors

The electrical bus cables must be terminated at the start and end of the line – even for short electrical bus cables – in accordance with the specification of the bus system used (see also chap. 3, p. 11).
 If there is an OZD 485 G12 BAS at the start or end of a data line, then the terminating resistor and the pull-up/pull-down resistors (if they exist) can be mounted directly on the repeater.

Recommended resistor type:
 load capacity 1/3 W, tolerance 5%

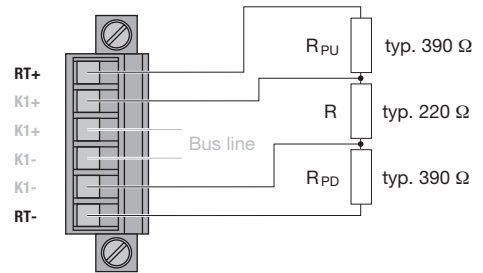

Fig. 11: Termination on the 6-pin screw terminal block (terminating resistor and pull-up/pull-down resistors)

5.6 Connecting the optic bus cables

- ▶ Verbinden Sie die einzelnen Repeater über ein Duplex LWL-Kabel mit BFOC/2,5 (ST[®]) Steckverbindern.
- ▶ Beachten Sie die maximale Länge der LWL-Kabel sowie die möglichen Fasertypen, die in den Technischen Daten angegeben sind.
- ▶ Ensure that one optical input \ominus and one optical output \ominus are connected to one another (crossover connection).
 The sticker on the side indicates the related BFOC sockets of the two ports.
- ▶ Ensure that the strain relief of the F/O cables is sufficient and observe their minimum bend radiuses.
- ▶ Seal unused BFOC sockets with the protection caps supplied. Ambient light can interfere with the network, especially if the environment is very bright. Dust which gets in can render the optical components unusable.

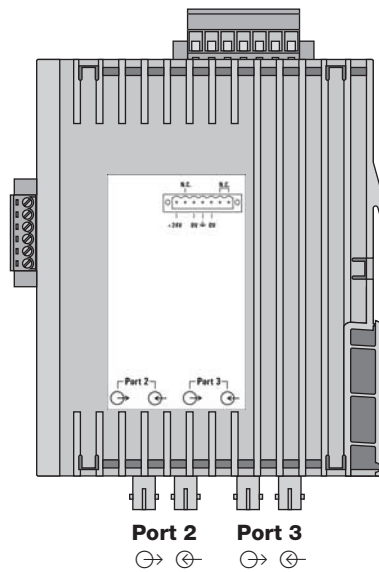

Fig. 12: Location of optical ports 2 and 3, with their respective inputs and outputs

5.7 Connecting the electric bus cables

- ▶ The bus cables are connected by means of the plugable screw terminal block on the front of the device.
- ▶ To connect the cables, loosen the screws on the top section and remove it. After connecting the bus cables and then plugging them in, do not forget to re-fasten the screw terminal block.

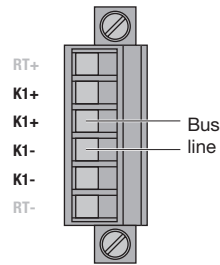



Fig. 13: Connecting the bus cables to the 6-pin screw terminal block

5.8 Connecting the function ground



There is no contact separation between the bus lines and the connection for the function ground. Therefore please observe the following safety instructions:

- ▶ Do not use bus lines to connect repeaters to device parts which have a different earth potential. The different voltages could destroy the repeaters!
- ▶ Do not connect bus lines which are partly or entirely laid outside buildings. If lightning strikes close by, this could destroy the repeaters. Use F/O cables for bus connections outside buildings!

- ▶ The shield of the data cable, together with the function ground connection, must be connected to an equipotential rail in the switch cabinet. The equipotential rails of the switch cabinets, which are connected to one another by means of an electrical RS 485 bus cable, must have a low-impedance connection to one another.
- ▶ The function ground of the repeater is effected by means of the  connection of the screw terminal block on top of the device.

5.9 Connecting the operating voltage supply

- ▶ Only supply the repeater with a stabilized **safety extra-low voltage (SELV)** in accordance with IEC/EN 60 950/VDE 0805, maximum +32 V (typically +24 V). It is supplied via the 7-pin terminal block on the top of the repeater.
- ▶ You can input the voltage supply via the terminal +24 V of the terminal block. The minus connection is indicated by “0 V”.

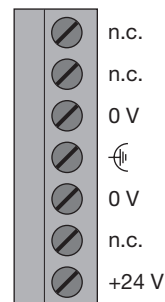

Fig. 14: Operating voltage supply – pin assignment on the 7-pin terminal block

5.10 Checking the LED indicators

- ▶ There are LEDs on the front of the device for diagnostic purposes. They are explained in chapter 7.1, p. 27.

6 Bus configurations

6.1 BITBUS

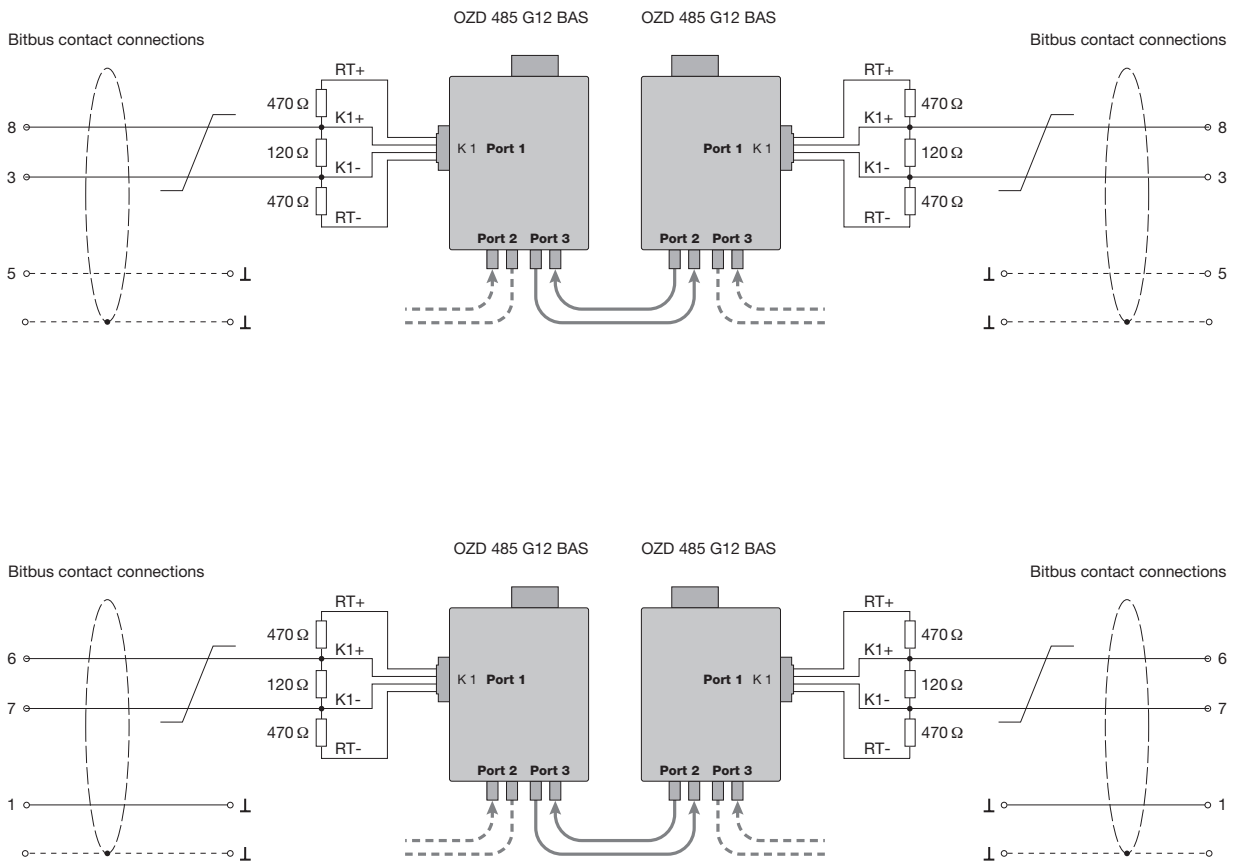

Fig. 15: Example of connection of OZD 485 G12 BAS to bitbus with twisted pair cable type A (above) or type B (below). The PIN numbers on the ends of the lines refer to the 9-pin sub-D connections prescribed in the standard.

6.2 Configuration of other bus systems

If you are using a collision-free RS 485 bus other than this named in chapter 6.1, please clarify which termination the bus system has and – derived from this – the type of tristate identification. The OZD 485 G12 BAS only supports RS 485 bus systems that have a high level in the idle phase (for tristate).

Comment:

All data rates from 0 - 1.5 Mbit/s NRZ are supported.

Should you need additional support, please contact our Service Center (for address, see chap. 7.4, p. 29).

7 Help with problems

7.1 LED displays

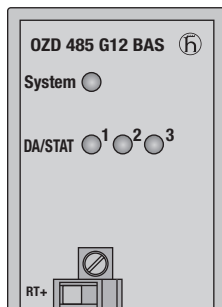

Fig. 16: LED indicators on the front panel

LED display	Possible causes
System <ul style="list-style-type: none"> ■ green ■ off 	<ul style="list-style-type: none"> – Repeater operating correctly – Supply voltage interrupted – Internal device error
DA/STAT 1 <ul style="list-style-type: none"> ■ yellow ■ off 	<ul style="list-style-type: none"> – Data received at port 1 – No input signal at port 1
DA/STAT 2 <ul style="list-style-type: none"> ■ green ■ yellow ■ off 	<ul style="list-style-type: none"> – Input signal at port 2 ok – Optical data received at port 2 – No input signal at port 2
DA/STAT 3 <ul style="list-style-type: none"> ■ green ■ yellow ■ off 	<ul style="list-style-type: none"> – Input signal at port 3 ok – Optical data received at port 3 – No input signal at port 3

7.2 Troubleshooting

If your RS485 network is not working correctly with OZD 485 G12 BAS, please check the following points:

- ▶ Try using the LED indicators (see chap. 7.1, p. 27) to find possible causes and try to resolve them.
- ▶ Are all the electrical bus lines terminated at both ends in accordance with the specifications of the bus system being used (even for short electrical bus lines)?
- ▶ Is the shielding (see chap. 5.1, p. 17 and 5.8, p. 22) connected?
- ▶ Is the function ground (see chap. 5.8, p. 22) connected?
- ▶ Are the lengths of the optical fibers within the specified value range (depends on the glass fiber being used)? See chapter 8, p. 31.

7.3 Problem reporting

If the transmission in the RS485 network is still not satisfactory after all the points in chapter 7.2 have been clarified, then please send answers to the following questions and the documents requested to our service hotline (for contact address, see chap. 7.4, p. 29):

1. Exact type designation of the OZD 485 G12 BAS. For identification purposes, please provide the order number printed on the device (18 digits).
2. Does the bus system to be transferred in the physical interface correspond to the standard RS 485?
3. Does the bus access procedure of the bus system used ensure that at any given time only one participant can access the bus?
Warning! Access procedures where there is a risk of collisions (e.g. CAN) are not permissible!
4. What type of tristate identification is being used by the bus system (permanent high or differential voltage - see chap. 3, p. 11)?
5. Is the field bus system operating in "half-duplex" or "full-duplex" mode?
6. Give as detailed a description of the error as possible in your own words.
7. Send us a detailed network plan with
 - the fiber type and fiber length,
 - the location and length of the electrical segments,
 - the values, the type (characteristic impedance with or without pull-up and pull-down resistors) and the position of the termination on the electrical bus segment.

8. What data rate is being used?
9. What is the status of the LEDs on the relevant OZD 485 G12 BAS?
10. Name and manufacturer of the field bus system?

Important!

If you do not provide complete answers to questions 1 to 10, we cannot process your query!

Note:

You can get the current version of this manual on the Internet at <http://www.hirschmann.com/> via the product search at the product.

You will find the version of this manual on every page of the manual, at the bottom opposite the page number.

7.4 Contact address

Contact address for technical support

Hirschmann Automation and Control GmbH
Stuttgarter Strasse 45 - 51
72654 Neckartenzlingen
Germany/Allemagne

Tel.: ++49 / 1805/ 14-1538

Fax: ++49 / 7127/ 14-1551

E-Mail: hac-support@hirschmann.de

Internet: <http://www.hirschmann.com>

8 Technical Data

Repeater	OZD 485 G12 BAS
Order No.	943 893-321
Voltage/power supply	
Operating voltage	NEC Class 2 power source 18 to 32 VDC (typically 24 VDC) Safety extra-low voltage (SELV/PELV) (redundant inputs decoupled), max. 5 A, buffer time min. 10 ms at 24 VDC
Current consumption at +18 VDC	110 mA
at +32 VDC	65 mA
Switched on peak value	150 mA max.
Power consumption	2.1 W
Signal transmission	
Transmission speed	0 ... 1,5 MBit/s NRZ
Signal processing time (any input/output)	<1.33 µs
Elektrischer Port	
Input signal/Output signal	RS 485 level
Connection capability	max. 31 terminal devices for each electrical segment
Optical interface	
Wavelength typ.	860 nm
Launchable optical power	
– in fiber G 50/125	–20 dBm
– in fiber G 62.5/125	–16 dBm
Receiver sensitivity	–30 dBm
Transmission distance with 3 dB system reserve/line attenuation	
– with fiber G 50/125 (3.0 dB/km)	0 - 2,3 km/10 dB
– with fiber G 62.5/125 (3.5 dB/km)	0 - 3,1 km/14 dB
Optical connector	BFOC/2.5 (ST [®])
Electromagnetic compatibility (EMC)	
Interference immunity for industry in accordance with EN 61000-6-2:2001	
Electrostatic discharging (ESD)	conforms to EN 61000-4-2; 4 kV contact discharge, 8 kV air discharge
Electromagnetic field	conforms to EN 61000-4-3; 10 V/m (80 MHz - 1000 MHz, 1400 MHz -2000 MHz)
Fast transients (burst)	conforms to EN 61000-4-4; 2 kV power line, 1 kV data line
Voltage surge	conforms to EN 61000-4-5; 1 kV data line, 1 kV power line symmetrical, 1 kV power line asymmetrical
Line-conducted interference voltages	conforms to EN 61000-4-6; 10 V (150 kHz - 80 MHz)
Emitted interference	conforms to EN 55022; Class A conforms to FCC CFR47 Part 15; Class A

Repeater	OZD 485 G12 BAS
Order No.	943 893-321
Climatic ambient conditions	
Ambient temperature	–25 °C to +70 °C (IEC 60068-2-1, IEC 60068-2-2)
Storage temperature	–25 °C to +80 °C (IEC 60068-2-14)
Relative humidity	<95 %, non-condensing (IEC 60068-2-30)
Air pressure	during operation: up to 2000 m (795 hPa) transport and storage: up to 3000 m (700 hPa)
Contamination level	2
Mechanical ambient conditions	
Vibrations	3 to 9 Hz, 3.5 mm amplitude (IEC 61131-2); 9 to 150 Hz, 1 g acceleration (IEC 61131-2)
Shock	15 g, 11 ms duration, 18 shocks (IEC 61131-2)
Protection class	IP 20
Weight	176 g
Dimensions (W x H x D, with connections)	35 x 156 x 114 mm
Housing material	Plastic PA6.6, aluminium

Hirschmann Automation and Control GmbH
Stuttgarter Strasse 45 - 51
72654 Neckartenzlingen
Germany/Allemagne

Tel.: ++49 / 1805/ 14-1538

Fax: ++49 / 7127/ 14-1551

E-Mail: hac-support@hirschmann.de

Internet: <http://www.hirschmann.com>